



AVENGER

Night Vision Monocular



OPERATION AND MAINTENANCE MANUAL

Important Export Restrictions! Commodities, products, technologies and services of this manual are controlled by the U.S. Department of State Office of Defense Trade Controls, in accordance with International Traffic in Arms (ITAR), Title 22, Code of Federal Regulations Part 120-130 and/or by the Export Administration Regulations (EAR) of U.S. Department of Commerce. At any time when a license or a written approval of the U.S. Government is applicable to it, it is illegal and strictly forbidden to export, intend to export, transfer in any other manner whatsoever, sell any hardware or technical data, provide any associated service to any non-U.S. resident, beyond or within the United States territory, until the valid license or written approval has been issued by the Departments of the U.S. Government having jurisdiction. Additionally U.S. law prohibits the sale, transfer, or export of items to certain restricted parties, destinations, and embargoed countries, as identified on lists maintained by the U.S. Department of State, the U.S. Department of Commerce, and the U.S. Department of Treasury. It is the responsibility of the Customer to be aware of these lists. The sale, transfer, transportation, or shipment outside of the U.S. of any product prohibited or restricted for export without complying with U.S. export control laws and regulations, including proper export licensing, documentation or authorization, is unlawful and may result in civil and/or criminal penalties and/or constitute a federal crime. Diversion contrary to U.S. law is strictly prohibited.



SAFETY SUMMARY

Before operating this product, carefully read and study this Operation and Maintenance Manual.

The Avenger is a precision electron-optical instrument, and requires careful handling. To avoid damage to the equipment or physical harm to the user when operating the Avenger, follow all WARNINGS, CAUTIONS and NOTES.

Below you will find definitions of the following alerts that appear throughout this Manual:

WARNING — Identifies a clear danger to the person operating the equipment.

CAUTION – Identifies risk of damage to the equipment.

NOTE – Serves to highlight essential procedures, conditions, and statements, or convey important instructional data to the user.



WARNING:

This product contains natural rubber latex which may cause allergic reactions! The FDA has reported an increase in the number of deaths that are associated with an apparent sensitivity to natural latex proteins. If you are allergic to latex, it is a good idea to learn which products contain it and strictly avoid exposure to those products.



WARNINGS:

- Always make sure your firearm is unloaded before you place the scope on the firearm. Reconfirm that the chamber is empty if you stop the procedure then resume later. Safe handling rules should be followed at all times.
- The light from the unit infrared (IR) illuminator is invisible to the unaided eye when used in total darkness. **However, the light can be detected by other Night Vision Devices (NVD).**
- To reduce the risk of detection by another NVD, avoid prolonged activation of the IR illuminator.
- The IR light is more detectable by an NVD when used in smoke, fog and rain. Avoid prolonged activation of the unit IR illuminator in these conditions.
- This product contains natural rubber latex, which may cause allergic reactions.
- The intensifier's phosphor screen contains toxic materials. Please note the following:
 - If the intensifier tube breaks, be **extremely careful** to avoid inhaling the phosphor screen material. DO NOT allow the material to come in contact with your mouth, eyes, or any open wounds on the skin.
 - If the phosphor screen material comes in contact with your skin, wash it off immediately with soap and water.
 - If you inhale or swallow any phosphor screen material, drink a lot of water, induce vomiting, and **seek medical attention as soon as possible.**

The information provided in this manual is for familiarization purposes only. The contents may undergo further changes with no commitment by Armasight® to notify customers of any updates.

Armasight® assumes no responsibility for any misprints or other errors that this manual may contain.

©2015 by Armasight. All rights reserved.

CAUTION:

- The Avenger is a precision electron-optical instrument, and must be handled carefully at all times to prevent damage to the device and danger to the user.
- To protect the intensifier tube, **do not remove** the lens cap of the Avenger when the monocular is being operated in daylight conditions, or when the device is not in use.
- Use of the Avenger in brightly lit conditions may damage the unit's intensifier tube.
- Bright light sources such as firelight, headlights, searchlights, etc. can damage the Avenger. Avoid exposing the unit to these types of light sources.
- Before removing the lens cap, verify that the photoreceiver is open.
- DO NOT forget to open the photoreceiver after completing your mission.
- DO NOT attempt to force the controls past their stopping points, as this may cause damage to the mechanisms.
- The unit may be badly damaged if the tripod on which it is mounted collapses or overturns. Remove the unit from the tripod if it is not within your reach.
- Before replacing the intensifier tube, confirm that it is no longer covered by warranty.
- Thoroughly dry each component of the Avenger before placing them in the storage case.

NOTES:

- The equipment requires some ambient light (moonlight, starlight, etc.) to operate.
- Performance of the device in nighttime conditions depends on the level of ambient light in the environment. Please remember the following:
 - The level of ambient light is reduced by the presence of clouds, shade, or objects that block natural light (trees, buildings, etc.).
 - The equipment is less effective when operated in shadows and other darkened areas.
 - The equipment is less effective when operated in rain, fog, sleet, snow, dust or smoke.
 - The equipment will not "see" through dense smoke.
- At operating temperatures below -20°C (-4°F), the use of an alkaline battery is not recommended, as the battery life will be severely reduced. Under said conditions, lithium-iron disulfide 1.5V AA batteries or their equivalent should be used.
- The built-in IR illuminator is intended for increased illumination, as needed, when viewing at a close distance of up to 20m.
- The Avenger is **not** a weapon sight. However, it can be used in conjunction with a collimator dot sight or laser aiming device.
- For the purpose of returning defective components, retain all packaging materials.

LIST OF CONTENTS

TITLE	PAGE
Safety Summary	2
List of Contents	4
List of Figures	5
List of Tables	6
How to Use This Manual	6
1. INTRODUCTION	7
1.1 General Information	7
1.1.1 Type of Manual	7
1.1.2 Model Number and Equipment Name	7
1.1.3 Purpose of Equipment	7
1.1.4 Reporting Equipment Improvement Recommendations	7
1.2 Warranty Information and Registration	8
1.2.1 Warranty Information	8
1.2.2 Limitation of Liability	8
1.2.3 Product Warranty Registration	8
1.2.4 Obtaining Warranty Service	9
1.3 List of Abbreviations	10
2. DESCRIPTION AND DATA	11
2.1 System Description	11
2.2 Specifications	13
2.3 Standard Components	14
2.4 Optional Equipment	15
2.5 Key Features	16
3. OPERATING INSTRUCTIONS	17
3.1. Installation and Mounting	17
3.1.1 Battery Installation	17
3.1.2 Mounting the Avenger to a Weapon with a Quick Release Picatinny Mount Adapter	18
3.1.3 Mounting an Long-Range IR Illuminator to the Avenger	18
3.1.4 Mounting the Avenger to a Weapon with an AIM PRO Advanced Aiming Mount	19
3.1.5 Mounting a Camera/Camcorder to the Avenger	19
3.1.6 Universal Camera Adapter Application	19
3.2 Controls and Indicators	20
3.2.1 Controls and Indicators	20
3.3 Operating Procedures	21
3.3.1 Operating Procedures	21
3.3.2 IR Illuminator Operations	22
3.3.3 Operating Under Changing Light Conditions	22
3.3.4 Avenger Shut-Down	23
3.4 Storage	23
3.4.1 Preparation for Storage	23

4. PREVENTIVE MAINTENANCE AND TROUBLESHOOTING	24
4.1 Preventive Maintenance Checks and Services	24
4.1.1 Preventive Maintenance Checks and Services (PMCS)	24
4.2 Troubleshooting	26
4.2.1 Operator Troubleshooting	26
4.3 Identification of Operational Defects	27
4.3.1 Operational Defects	27
4.3.2 Cosmetic Blemishes	27
4.4 Maintenance	29
4.4.1 General	29
4.4.2 Cleaning Procedures	29
4.4.3 Battery Removal and Replacement	30
4.4.4 Goggle Kit Maintenance	30
4.5 Return Instructions	30
APPENDIX	31
A. Avenger List of Spare Parts	31
B. Product Warranty Registration Card	33
Alphabetical Index	35

LIST OF FIGURES

FIGURE	TITLE	PAGE
2-1	Avenger Night Vision Monocular	12
2-2	Avenger Standard Components	14
3-1	Battery Installation	17
3-2	Mounting the Avenger to a Weapon with a Quick Release Picatinny Mount Adapter	18
3-3	Mounting an IR Illuminator to the Avenger	18
3-4	Mounting the Avenger to a Weapon with an AIM PRO	19
3-5	Mounting a Camera/Camcorder to the Avenger	19
3-6	Universal Camera Adapter Application	20
3-7	Avenger Controls	20
3-8	IR Illuminator Operations	22
3-9	Photoreceiver	23
4-1	Shading	27
4-2	Edge Glow	27
4-3	Emission Points and Bright Spots	28
4-4	Fixed-Pattern Noise	28
4-5	Chicken Wire	29
A-1	Avenger Spare Parts	31

LIST OF TABLES

TABLE	TITLE	PAGE
2-1	Avenger System Description	12
2-2	Optical Data	13
2-3	Electrical Data	13
2-4	Mechanical Data	13
2-5	Environmental Data	13
2-6	Avenger Standard Components	14
2-7	Avenger Optional Equipment	15
3-1	Avenger Controls and Indicators	21
4-1	Preventive Maintenance Checks and Services	24
4-2	Operator Troubleshooting	26
A-1	Avenger List of Spare Parts	31

HOW TO USE THIS MANUAL

USAGE

You must familiarize yourself with the entire manual before operating the equipment. Before performing any kind of maintenance on your device, read the section on maintenance in its entirety. Follow all WARNINGS, CAUTIONS, and NOTES.

MANUAL OVERVIEW

This manual contains sections on Operating and Maintaining the Avenger Night Vision Monocular. The list of Spare Parts can be found in Appendix A. The Product Warranty Registration Card can be found in Appendix B.

INTRODUCTION

1.1 GENERAL INFORMATION

1.1.1 TYPE OF MANUAL

Operation and Maintenance (including a List of Spare Parts).

1.1.2 MODEL NUMBER AND EQUIPMENT NAME

Avenger Night Vision Monocular.

1.1.3 PURPOSE OF EQUIPMENT

To provide the operator with the ability to observe at night under moonlight and starlight conditions.

The Avenger can be used as a handheld or weapon-mounted device to allow short-range surveillance and weapon firing. The Avenger can be mounted in front of a camcorder or camera for night photography, or it can be affixed to a rifle with a variety of different mounts.

1.1.4 REPORTING EQUIPMENT IMPROVEMENT RECOMMENDATIONS

Recommendations from the user for improvements to the device are encouraged.

Mail your comments to Armasight Inc., 815 Dubuque Avenue, South San Francisco, CA 94080, USA.

Or, send an email to info@armasight.com.

1.2 WARRANTY INFORMATION AND REGISTRATION

1.2.1 WARRANTY INFORMATION

This product is guaranteed to be free from manufacturing defects in material and workmanship under normal use for a period of two (2) years from the date of purchase. In the event that a defect covered by the below warranty occurs during the applicable period stated above, Armasight, at its discretion, will either repair or replace the product; such action on the part of Armasight shall be the full extent of Armasight's liability, and the Customer's sole and exclusive reparation. This warranty does not cover a product if it has (a) been used in ways other than its normal and customary manner; (b) subjected to misuse; (c) subjected to alterations, modifications or repairs by the Customer or by any party other than Armasight without prior written consent of Armasight; (d) special order or "close-out" merchandise or merchandise sold "as-is" by either Armasight or the Armasight dealer; or (e) merchandise that has been discontinued by the manufacturer and either parts or replacement units are not available due to reasons beyond the control of Armasight. Armasight shall not be responsible for any defects or damage that in Armasight's view are a result from the mishandling, abuse, misuse, improper storage or improper operation of the device, including use in conjunction with equipment that is electrically or mechanically incompatible with, or of inferior quality to, the product, as well as failure to maintain the environmental conditions specified by the manufacturer. CUSTOMER IS HEREBY NOTIFIED THAT OPERATION OF THE EQUIPMENT DURING DAYLIGHT HOURS OR UNDER ANY EXCESSIVE LIGHT CONDITIONS MAY PERMANENTLY DAMAGE THE INTERNAL COMPONENTS OF THE UNIT AND SAID DAMAGE WILL NOT BE COVERED UNDER THIS WARRANTY. This warranty is extended only to the original purchaser. Any breach of this warranty shall be enforced unless the customer notifies Armasight at the address noted below within the applicable warranty period.

The customer understands and agrees that except for the foregoing warranty, no other warranties written or oral, statutory, expressed or implied, including any implied warranty of merchantability or fitness for a particular purpose, shall apply to the product. All such implied warranties are hereby and expressly disclaimed.

1.2.2 LIMITATION OF LIABILITY

Armasight will not be liable for any claims, actions, suits, proceedings, costs, expenses, damages or liabilities arising out of the use of this product. Operation and use of the product are the sole responsibility of the Customer. Armasight's sole undertaking is limited to providing the products and services outlined herein in accordance with the terms and conditions of this Agreement. The provision of products sold and services performed by Armasight to the Customer shall not be interpreted, construed, or regarded, either expressly or implied, as being for the benefit of or creating any obligation toward any third party of legal entity outside Armasight and the Customer; Armasight's obligations under this Agreement extend solely to the Customer. Armasight's liability hereunder for damages, regardless of the form or action, shall not exceed the fees or other charges paid to Armasight by the customer or customer's dealer. Armasight shall not, in any event, be liable for special, indirect, incidental, or consequential damages, including, but not limited to, lost income, lost revenue, or lost profit, whether such damages were foreseeable or not at the time of purchase, and whether or not such damages arise out of a breach of warranty, a breach of agreement, negligence, strict liability or any other theory of liability.

1.2.3 PRODUCT WARRANTY REGISTRATION

In order to validate the warranty on your product, Armasight must receive a completed Product Warranty Registration Card for each unit, or the Customer can complete a warranty registration on our website, at www.armsight.com. Please complete the included form (Appendix B) and immediately mail it to our Service Center:

Armasight Inc.
815 Dubuque Avenue
South San Francisco, CA 94080
United States of America

1.2.4 OBTAINING WARRANTY SERVICE

To obtain warranty service on your unit, the End-user (Customer) must notify the Armasight service department via email. Send any requests to service@armasight.com to receive a Return Merchandise Authorization number (RMA). When returning any device, please take in the product to your retailer, or send the product, postage paid and with a copy of your sales receipt, to Armasight Corporation's service center at the address listed above. All merchandise must be fully insured with the correct postage; Armasight will not be responsible for improper postage or merchandise that becomes lost or damaged during shipment. When sending product back, please clearly write the RMA# on the outside of the shipping box. Please include a letter that indicates your RMA#, the Customer's Name, a Return Address, reason for the return, Contact information (valid telephone numbers and/or an e-mail address), and proof of purchase that will help us to establish the valid start date of the warranty. Product merchandise returns that do not have an RMA# listed may be refused, or a significant delay in processing may occur. Estimated Warranty service time is 10-20 business days. The End-user/ Customer is responsible for postage to Armasight for warranty service. Armasight will cover return postage/ shipping after warranty repair to the End-user/ Customer only if the product is covered by the aforementioned warranty. Armasight will return the product after warranty service by domestic UPS Ground service and/ or domestic mail. Should any other requested, required or international shipping methods be necessary, the postage/ shipping fee will be the responsibility of the End-user/ Customer.

1.3 LIST OF ABBREVIATIONS

C	Celsius (Centigrade)
CCW	counterclockwise
Cont'd	Continued
CW	clockwise
Dia	diameter
F	Fahrenheit
FOV	Field of View
g	gram
Gen	Generation
H	Height
hr	hour
IR	infrared
IT	Intensifier Tube
L	Length
LED	Light Emitting Diode
lx	lux
m	meter
mA	milliamperere
min	minute
mm	millimeter
mW	milliwatt
nm	nanometer
No	Number
NV	Night Vision
NVD	Night Vision Device
Para	Paragraph
PMCS	Preventive Maintenance Checks and Services
QRM	Quick Release Mount
QTY	Quantity
RMA#	Return Merchandise Authorization number
s	second
seq	sequence
SR	Service Representative
VDC	Volts Direct Current
V	Volt
W	Width

DESCRIPTION AND DATA

2.1 SYSTEM DESCRIPTION

The Avenger is a hand-held, or weapon-mounted night vision system that allows the user to operate it while conducting short-range surveillance or while firing weapons in both moonlight and starlight conditions.

The Avenger utilizes the principle of intensification of the residual light that is reflected from the surrounding objects. The optical system of the unit consists of an objective lens, an intensifier tube (IT), and an eyepiece.

The Avenger automatic brightness adjustment system retains the same gain (image brightness), even under unsteady light conditions.

The Avenger automatic protective system controls illumination through a photoreceiver. If the illumination level surpasses 100-300 lx for more than 10s, the unit will shut off automatically.

Automatic shut-off system automatically turns off the device when it is unused (controls are not touched) for 60 minutes. The automatic shut-off function preserves battery life should the device be inadvertently activated.

A built-in IR illuminator makes it possible to use the unit in low light or total darkness.

The Avenger is powered by a single AA or CR123A battery. Battery adapter is included.

The Avenger uses LED lights to indicate illumination level, low battery, and to show the user that the IR illuminator is on.

The Armasight Avenger can be equipped with high-performance Gen 2+ and Gen 3 IITs including Green Phosphor or White Phosphor IITs, which provide users with natural B&W night vision displays.

NOTE:

The equipment requires some light (moonlight, starlight, etc.) to operate. Performance of the device depends upon the level of ambient light in the environment. Please remember the following:

- The level of ambient light in the environment is reduced by the presence of clouds, shade, or objects that block natural light (trees, buildings, etc).
- The equipment is less effective when operated in shadows and other darkened areas.
- The equipment is less effective when operated in rain, fog, sleet, snow, or smoke.
- Under starlight conditions, particularly in low-contrast environments such as snow-covered territory, sandy deserts, large bodies of water or grassy hills, the visibility may degrade, thereby disguising or masking changes in terrain.
- The equipment will not “see” through dense smoke.

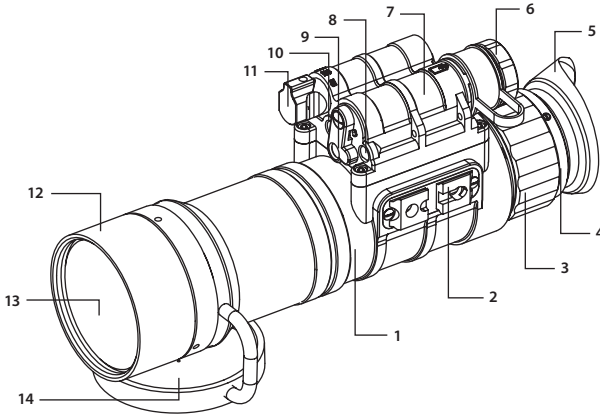

FIGURE 2-1. AVENGER NIGHT VISION MONOCULAR

TABLE 2-1. AVENGER SYSTEM DESCRIPTION

ITEM	DESCRIPTION	ITEM	DESCRIPTION
1	Body	8	Photo Receiver
2	Rail	9	Pivotal Focusing Lens
3	Eyepiece Ring	10	IR Illuminator
4	Eyepiece	11	Turn-pull Function Switch
5	Eye-cup	12	Focus Ring
6	Battery Cap	13	Lens
7	Battery Compartment	14	Lens Cap

2.2 SPECIFICATIONS

TABLE 2-2. OPTICAL DATA

ITEM	DATA
Magnification:	3X
Lens:	
— Focal Length	80 mm
— Lens F/number	1:1.65
Focus Range:	5 m to infinity
FOV:	12.6°
Exit Pupil Diameter	10 mm
Eye Relief	21.5 mm
Eyepiece Diopter Adjustment	-5 to +5 diopters
Built-in IR Illuminator:	
— Power	50 mW
— Illumination Range	up to 20 m
— Illumination Wavelength	850 nm

TABLE 2-3. ELECTRICAL DATA

ITEM	DATA
Battery	One AA (1.5 V) or one CR123A (3 V) *
Continuous Operation** at 20 °C (68°F):	
- AA Alkaline Battery	40
- CR123A Lithium Battery	60

* Any AA or CR123 type rechargeable batteries with voltage from 1.2V to 3.7V can be used

** With IR illuminator off.

TABLE 2-4. MECHANICAL DATA

ITEM	DATA
Overall Dimensions	212 x 58 x 84 mm / 8.3 x 2.2 x 3.3 in
Weight (w/o battery)	670 g / 1.5 lbs

TABLE 2-5. ENVIRONMENTAL DATA

ITEM	DATA
Operating Temperature	-40 to +50 °C
Storage Temperature	-50 to +70 °C
Humidity	95%, 25°C to 40°C for 48 hr
Illumination Required	Natural night illumination (overcast starlight to moonlight)
Environmental Rating	Water and fog-resistant

2.3 STANDARD COMPONENTS

The standard components of the Avenger are shown in Figure 2-2 and listed in Table 2-6. The ITEM NO. column indicates the number used to identify items in Figure 2-2.

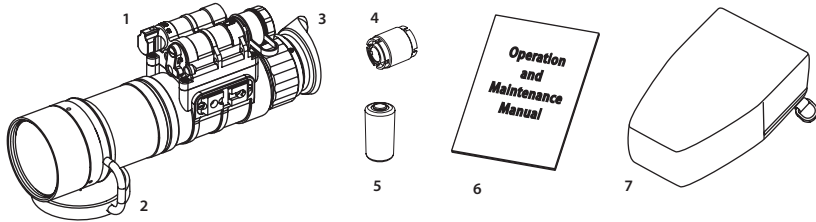

FIGURE 2-2. AVENGER STANDARD COMPONENTS

TABLE 2-6. AVENGER STANDARD COMPONENTS

ITEM NO.	DESCRIPTION	QUANTITY
1	Night Vision Monocular	1
2	Lens Cap	1
3	Eye-cup	1
4	Battery Adapter	1
5	Battery	1
6	Operation and Maintenance Manual	1
7	Carrying Case	1

1) Armasight Avenger Night Vision Monocular

Monocular night vision device with unity magnification.

2) Lens Cap

A cap used to protect the lens and to be used when testing the unit in daylight.

3) Eye-cup

A rubber cup used to protect the eyepiece as well as provide comfort for the operator.

4) Battery Adapter

Allows of use of a single CR123 or AA batteries.

5) Battery

A single battery used to power the unit.

6) Operation and Maintenance Manual

Provides safety information, equipment description, mounting procedures, operating instructions, and preventive maintenance checks and service (including a List of Spare Parts).

7) Carrying Case





A protective case used for storing and carrying of the Avenger and its accessories.

2.4 OPTIONAL EQUIPMENT

Optional items are shown and listed in Table 2-7.

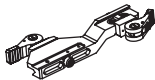
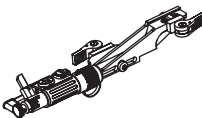
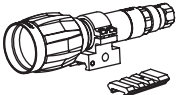
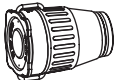
The PART NO. column indicates the primary number used by the manufacturer to identify an item.

TABLE 2-7. AVENGER OPTIONAL EQUIPMENT

IMAGE	DESCRIPTION	PART NO.
	Quick Release Picatinny Mount Adapter #26 Small arms adapter that allows the Avenger to be mounted on a weapon using Picatinny Mil 1913 rail.	ANAM000004
	AIM PRO-L Advanced Integrated Mount Long Allows the user to quickly convert the Avenger into a weapon sight.	ANKI000049
	XLR-IR850 Detachable X-Long Range Infrared Illuminator w/Dovetail to Weaver Transfer Piece #21, Rechargeable Battery, and Charger A detachable LED extra long-range infrared illuminator with a wide, adjustable beam angle (4 to 35 degrees). Should be used when there is little to no ambient light. Comes fully assembled with a dedicated mount in order to be installed on a Picatinny/Weaver rail. Dovetail to Weaver Transfer Piece #21 is also included.	ANKIXLR017
	XLR-IR Afocal Doubler Doubles the distance of XLR-IR850 IR Illuminator beam. Comes complete with an thread adapter #174.	ANAF18XXLR
	Extended Rail Adapter #85 A mounting system used to install a day scope behind the Avenger on a weapon, using a short-mounting Picatinny/Weaver rail.	ANAM000045
	Camera Adapter #47 An adapter with step down ring that allows the Avenger to be attached to any 35 mm SLR camera or 8mm camcorder.	ANAM000016
	Universal Camera Adapter #45 Allows the Avenger to be attached to a variety of camera systems.	ANAM000006
	Hard Shipping/Storage Case #101 A protective case used for the shipping/ storage of the Avenger and its accessories.	ANH000001

2.5 KEY FEATURES

- Automatic bright light cut-off system to protect the intensifier tube
- LED lights visible in the eyepiece viewing area that indicate operation of the bright light cut-off system and IR illuminator, as well as to alert the user of a low battery
- Built-in IR illuminator with pivotal lens to select between IR spot and flood beam
- Lightweight
- Compact and robust design
- Easy to operate
- Serviceability under severe conditions
- High-performance
- Highly reliable
- Automatic shut-off system
- Powered by single CR123A or AA battery
- Weapon-mountable (with optional adapter)
- Adaptable for use with cameras
- Compatibility with most weapons, IR laser aiming/ illuminating devices, reflex sights, and scopes
- Water and fog-resistant
- Limited two-year warranty

OPERATING INSTRUCTIONS

3.1 INSTALLATION AND MOUNTING

CAUTION:

To protect the intensifier tube when the sight is not in use or when it is being operated in daylight, keep the protective lens cap securely fitted over the lens.

3.1.1 BATTERY INSTALLATION

The Avenger operates on a single CR123A or AA battery.

Depending on the size of the battery used, it may be necessary to reposition the battery adapter within the battery cap.

NOTE:

If operating the device at temperatures below -20°C (-4°F), the use of an alkaline battery is not recommended, as the severe cold will adversely affect the life of the battery. In these conditions, it is recommended that you use a lithium-iron disulfide 1.5V AA battery, or its equivalent.

Install the CR123A battery as follows:

1. Unscrew the battery cap (A) and insert the CR123A battery (B), observing the polarity markings on the body of the device.
2. With the battery adapter (C) installed, screw the battery cap (A) back on securely.

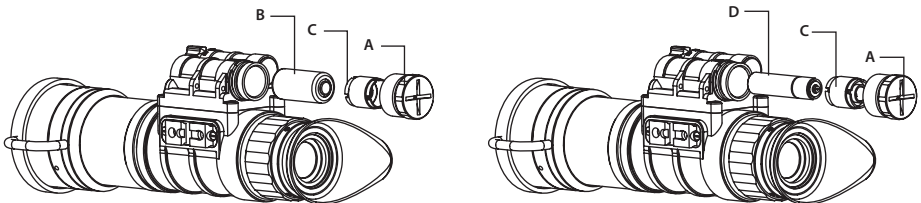

FIGURE 3-1. BATTERY INSTALLATION

Install the AA battery as follows:

1. Unscrew the battery cap (A).
2. Unscrew the battery adapter (C) from the cap, turn it around, and screw in the other end.
3. Insert the AA battery (D), observing the polarity markings as indicated on the body of the device.
4. Screw the battery cap (A) back into place.

3.1.2 MOUNTING THE AVENGER TO A WEAPON WITH A QUICK-RELEASE PICATINNY MOUNT ADAPTER

WARNING:

Always make sure your firearm is unloaded before you place the scope on the firearm. Reconfirm that the chamber is empty if you stop the procedure then resume later. Safe handling rules should be followed at all times.

To mount the Avenger to a weapon using an optional quick-release Picatinny mount adapter (QRM), perform the following:

1. While pushing down on the lever holder (C), turn the lever (B) backwards to loosen the QRM clamping device (A).
2. Install the QRM on the weapon rail by inserting the stop (not shown in Figure 3-2) into one of transverse slots of the weapon rail.
3. To secure the QRM onto the weapon rail, turn the lever (B) forward. Secure the clamping device (A) tightly to the weapon rail. To adjust the force of the lever clamp, loosen or tighten the nut (D) as necessary:
 - When the clamping device (A) unlocked, push the lever holder (C) so that the nut (D) gets out of its hollow.
 - To tighten/loosen clamping device, turn the nut (D) CW/CCW, respectively, by one-two increments (the eight-sided nuts of the AIM clamping devices fit their hollows only if turned in one of the discrete positions), when the holder (C) pushed. Just as the holder (C) released, backmoving springs makes the nut (D) get back into its hollow.
 - Check to ensure the clamping device holds weapon/NVM rail firmly.

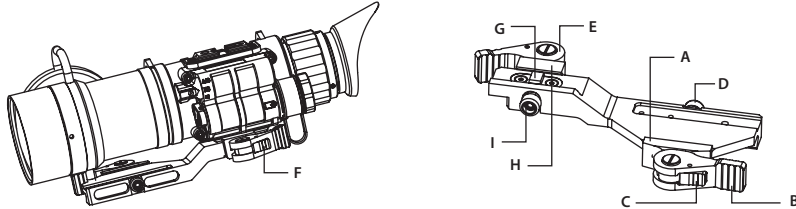

FIGURE 3-2. MOUNTING THE AVENGER TO A WEAPON WITH A QUICK-RELEASE PICATINNY MOUNT ADAPTER

4. While pushing down on the lever holder (F), turn the lever (E) forward.
5. Install the Avenger on the QRM rail by inserting the stop (G) into the transverse slot of the unit rail.
6. Attach the Avenger to the QRM rail by turning the lever (E) backwards. Secure the QRM clamping device (H) tightly to the Avenger rail. To adjust the force of the lever clamp, loosen or tighten the nut (I) as necessary.

3.1.3 MOUNTING AN LONG-RANGE IR ILLUMINATOR TO THE AVENGER

To mount an IR illuminator to the Avenger, use the Dovetail to Weaver Transfer Piece. Perform the following steps:

1. Install the transfer piece (A) onto one of the Avenger rails.
2. Tighten the two fixing screws (B) on the transfer piece.
3. Loosen the IR illuminator fixing screw (C).
4. Mount the IR illuminator on the Weaver rail of transfer piece and tighten the fixing screw (C).

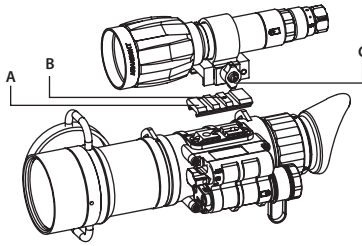

FIGURE 3-3. MOUNTING AN IR ILLUMINATOR TO THE AVENGER

3.1.4 MOUNTING THE AVENGER TO A WEAPON WITH AN AIM PRO ADVANCED INTEGRATED MOUNT

The clamping system of the Advanced Integrated Mount (AIM) is the same as is seen on the QRM. To mount the Avenger to a weapon with an AIM, see Part 3.1.2 of this Manual. This section details mounting instructions and procedures for the QRM.

For more information on the use of an AIM PRO, see the AIM PRO User's Manual.

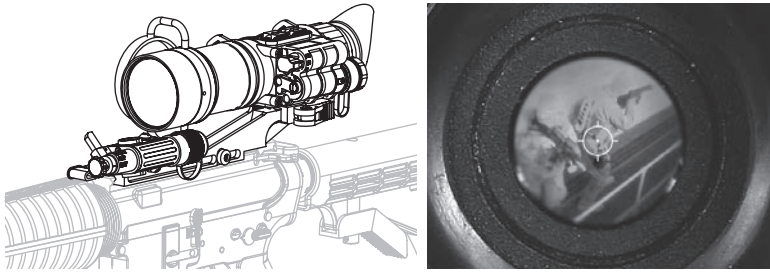

FIGURE 3-4. MOUNTING THE AVENGER TO A WEAPON WITH AN AIM PRO

3.1.5 MOUNTING A CAMERA/ CAMCORDER TO THE AVENGER

To mount any 35mm SLR photographic camera or 8mm camcorder to the Avenger, use the optional camera adapter and perform the following:

1. Using the (M37x0.75 threaded) adapter ring (B), screw the (M52x0.75 threaded) adapter (A) into the front lens of the photographic camera or video camera.
2. Remove the eyecup from the Avenger eyepiece.
3. Connect the adapter with the eyepiece and tighten the three fixing screws (C) located on the adapter.

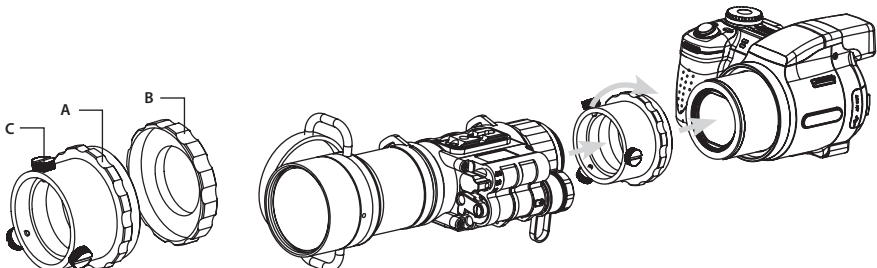

FIGURE 3-5. MOUNTING A CAMERA/ CAMCORDER TO THE AVENGER

3.1.6 UNIVERSAL CAMERA ADAPTER APPLICATION

To mount the Avenger (affixed with a camera or video recorder) to a tripod, you will need a universal camera adapter. Mount the connected devices to a tripod as follows:

1. Screw the adapter onto the tripod.
2. Remove the eyecup from the Avenger eyepiece.
3. Install the Avenger on the adapter rail (A) and tighten the fixing screw (B).
4. Install the camera on the adapter rail (C) and insert the fixing screw (D) into the tripod socket of the camera. Tighten the fixing screw.
5. Loosen the screws one by one. Align the optical axis of the Avenger with the camera objective. Tighten the screws (E and F).
6. To focus the image, loosen the screw (G) and adjust the distance between the monocular and the camera's eyepiece. Tighten the screw (G).

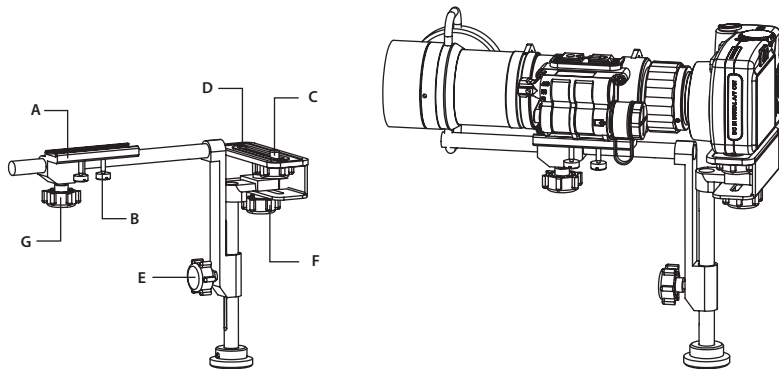

FIGURE 3-6. UNIVERSAL CAMERA ADAPTER APPLICATION

3.2 CONTROLS AND INDICATORS

3.2.1 CONTROLS AND INDICATORS

The Avenger controls and indicators are defined in Table 3-1.

The Avenger controls are shown in Figure 3-7.

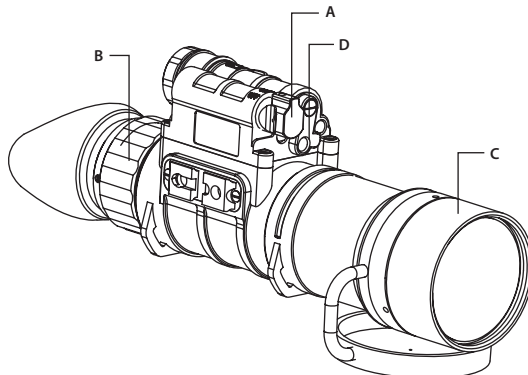

FIGURE 3-7. AVENGER CONTROLS

CAUTION:

DO NOT over-adjust the controls by forcing them past their stopping points.

TABLE 3-1. AVENGER CONTROLS AND INDICATORS

CONTROL/INDICATOR	FUNCTION
Turn-pull Function Switch (Figure 3-7, A)	OFF position — the unit is off.
	ON position — the unit is on (IT powered). Turn the unit on by turning the switch CCW from OFF to ON.
	IR position — the unit is on, and the IR illuminator is activated. Activate the IR illuminator by pulling it out and turning the switch CW from ON to the IR position.
Eyepiece Ring (Figure 3-7, B)	Adjusts the unit diopter. The total dioptric range is covered in a 1/2 ring revolution.
Focusing Ring (Figure 3-7, C)	Focuses the lens. Adjusts for sharpest view of the scene. The total focus range is covered in a 1/3 ring revolution.
Pivotal Focusing Lens (Figure 3-7, D)	Allows the user to choose between the following: 1. The IR illuminator spot beam. When the pivotal focusing lens is placed in the leftmost position of the window of the IR illuminator, the photoreceiver is open. 2. The IR illuminator flood beam. When the focusing lens is placed in the center position, the photoreceiver is opened. 3. The photoreceiver will close when the focusing lens is placed in the rightmost position.
Built-in LED Indicators	A GREEN GLOW in the eyepiece viewing area indicates excessive light conditions. After 10 s of exposure to bright light, the intensifier will shut off automatically. The unit will turn back on again when moved away from the excessive light.
	A PERMANENT RED GLOW in the eyepiece viewing area indicates that the IR illuminator is operating.
	A FLASHING RED LIGHT in the eyepiece viewing area indicates that the battery is low.

3.3 OPERATING PROCEDURES

3.3.1 OPERATING PROCEDURES

These procedures should be performed under nighttime conditions only.

CAUTION:

Use of the Avenger brightly lit conditions may damage the unit's intensifier tube.

1. Verify that the battery is installed as indicated on the monocular body.
2. Make a visual estimation of the illumination level in the viewing area. The required level of illumination is less than 1 lx (late twilight sky conditions).
3. Remove the lens cap and place it over the housing of the lens.

CAUTION:

Before removing the objective lens cap, verify that the photoreceiver is open.

4. Turn the function switch ON. After a slight delay, a green glow will appear in the eyepiece of the monocular.
5. Adjust the unit diopter by rotating the ring of the eyepiece.
6. Observe the scene. Rotate the focus ring until the image is clear and sharp.

CAUTION:

Bright sources such as firelight, headlights, searchlights, etc. can damage the Avenger. Avoid exposing the unit to these types of light sources.

NOTE:

If the automatic shut-off system automatically turns off the device when it is used you need turn the operation switch to OFF position and then back to ON position for continuing the operation.

3.3.2 IR ILLUMINATOR OPERATIONS

CAUTION:

When operating the device in extremely dark conditions, the light from the unit's IR illuminator will be invisible to the unaided eye. However, the light can be detected by other NVDs.

NOTE:

The built-in IR illuminator is designed to provide additional illumination (when needed) while viewing scenes or targets from a short distance (up to 20m).

1. To activate the IR illuminator, turn the monocular on. Pull the IR illuminator out and flip the turn-pull function switch (A) CW from ON to the IR position. A red light will appear in the eyepiece to indicate that the IR illuminator is operating.
2. Focus the IR light, if necessary, by placing the pivotal focusing lens (B) onto the IR illuminator output window (C).

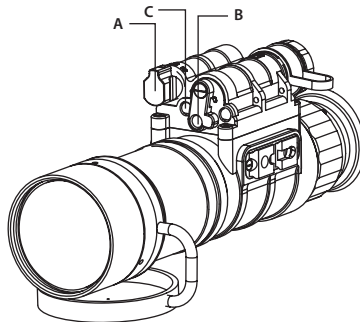

FIGURE 3-8. IR ILLUMINATOR OPERATIONS

3.3.3 OPERATING UNDER CHANGING LIGHT CONDITIONS

If the ambient light level exceeds the limit of 100-300 lx for more than 10 s, the Avenger automatic protective system will shut off the intensifier tube. If a mission must be carried out in changing light conditions, the user can shut down the protective system manually by closing the photoreceiver (A) with the pivotal focusing lens.

CAUTION:

DO NOT forget to open the photoreceiver after completing your mission.

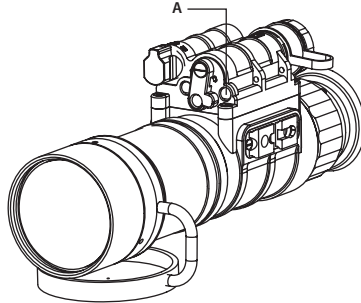

FIGURE 3-9. PHOTORECEIVER

3.3.4 AVENGER SHUT-DOWN

1. Turn the function switch to OFF. The green glow of the viewing area will fade to black.
2. Secure the lens cap over the objective lens.
3. If necessary, remove the unit from the rail. Remove the unit by following the mounting instructions in reverse.
4. Unscrew the battery cap and take out the battery. Replace the battery cap. Do not store the unit with the battery still in it.
5. Store the unit and all accessories in the case.

3.4 STORAGE

3.4.1 PREPARATIONS FOR STORAGE

Prepare the Avenger for storage as follows:

1. Verify that the Avenger and all accessories are clean and dry before returning them to the storage case.
2. Secure the cap over the objective lens.
3. Remove the battery.
4. Place the Avenger and accessories in the appropriate locations in the case, and close the cover.

PREVENTIVE MAINTENANCE AND TROUBLESHOOTING

4.1 PREVENTIVE MAINTENANCE CHECKS AND SERVICES

4.1.1 PREVENTIVE MAINTENANCE CHECKS AND SERVICES (PMCS)

Table 4-1: Preventive Maintenance Checks and Services has been provided so that you can keep your equipment operable and in good condition.

Perform all functional tests in the order listed in Table 4-1.

Operating Procedures are detailed in Chapter 3.

A. Cautions

Always observe any CAUTIONS that appear in the table.

B. Explanation of Table Entries

SEQ NO. column. Sequence numbers are for reference and appear in the order required to perform checks and services.

LOCATION/ITEM TO CHECK/SERVICE column. Indicates the location and the item to be checked or serviced.

PROCEDURE column. Details the checking/ servicing procedure.

NOT FULLY MISSION CAPABLE IF column. Indicates what faults will prevent your equipment from operating successfully.

TABLE 4-1. PREVENTIVE MAINTENANCE CHECKS AND SERVICES

SEQ NO.	LOCATION ITEM TO CHECK/SERVICE	PROCEDURE	NOT FULLY MISSION CAPABLE IF
BEFORE OPERATION CHECKS			
1	Completeness	Open the carrying case and inventory items by means of comparing with the data specified in this manual.	Items are missing.
2	Soft Carrying Case	Shake out loose dirt or foreign material. Inspect for tears, cuts, excess wear or damage to the mounting clips.	
3	External Surfaces	Inspect for cracks or damage. Scratches and gouges are OK if operation is not affected.	Cracked or damaged.
4	Lens Cap	Inspect for cracked, torn, or missing lens caps.	Cap is torn or cut. Cup is not secured to the housing of the lens.

TABLE 4-1. CONTINUED

SEQ NO.	LOCATION ITEM TO CHECK/SERVICE	PROCEDURE	NOT FULLY MISSION CAPABLE IF
5	Eyecup	Inspect for dirt, dust. Inspect for cracked or torn, bent, broken or improperly fitting eyecup. If necessary, clean as per Para 4.4.2.	Cup torn or cut.
6	Battery Adapter/ Compartment/ Cap	Verify that the battery adapter is present. Inspect for corrosion, moisture, corroded or defective contacts. Verify that the o-ring is present.	Adapter is missing, contacts damaged or corroded, or o-ring is missing.
7	Function Switch	Check the switch for operation (without a battery).	Switch has no definite stopping points. Switch knob is broken or missing.
8	Pivotal Focusing Lens	Check to make sure pivotal focusing lens is present.	Pivotal focusing lens is missing.
9	Lenses	Inspect optical surfaces for dirt, fingerprint residue, scratches, chips, or cracks.	Scratches or chips hinder vision with Avenger turned on. Cracks are present. Photoreceiver damaged. Pivotal focusing lens damaged.
10	Focusing Ring	Rotate the focusing ring to ensure free movement (range is approximately 1/3 turn).	Ring gets stuck or adversely affects the user's ability to properly focus the unit.
11	Eyepiece Ring	Rotate the eyepiece ring to make sure the eyepiece is not too tight or too loose. Range is approximately 1/2 turn.	Ring gets stuck, is too loose, or adversely affects the user's ability to properly adjust the diopter.
12	Optional Equipment	Inspect optional items for dirt, or corrosion, damage, and missing parts. Check for proper operation. If necessary, clean as detailed in Part 4.4.2.	Equipment is damaged or parts are missing.

OPERATIONAL CHECKS

CAUTION:

Do not activate the Avenger in daylight unless the lens cap is on, or you are operating under dark conditions.

CAUTION:

Do not forget to open the photoreceiver after finishing operational checks.

NOTE:

Daylight checks are described below.

13	Function Switch	Install the battery. Verify that the photoreceiver is open. Turn the switch from OFF to ON. Look for the green glow in eyepiece (it should appear after a slight delay), and wait about 10 s for image to disappear. Look for a flashing red light in eyepiece viewing area. Close the photoreceiver by placing the pivotal focusing lens in rightmost position. Pull out the IR and turn the switch from ON to the IR position. Look for a permanent red glow in the eyepiece viewing area. Turn the switch from IR to ON position.	Image is present. Red light is flashing. Permanent red glow is absent
14	Viewed Image	Inspect for any operational defects (refer to Part 4.3.1: Identification of Operational Defects).	Shading, edge glow, flashing, flickering, and intermittent operation, or excessive cosmetic defects are found.

AFTER CHECKING PROCEDURES

15		Turn the unit OFF. Verify that the green glow fades from the eyepieces. <hr/> Remove the battery. <hr/> Return the unit and all accessories to the soft carrying case.	
----	--	--	--

4.2 TROUBLESHOOTING

4.2.1 OPERATOR TROUBLESHOOTING

The purpose of troubleshooting is to identify the most frequently occurring equipment malfunctions, their probable causes, and the corrective actions required to fix them.

Table 4-2 lists common malfunctions that may occur during the operation or maintenance of the Avenger. Perform the tests, inspections, and corrective actions in the order listed in the table.

This table does not list all of the malfunctions that may occur with your device, or all of the tests and corrective actions that may be necessary. If you experience an equipment malfunction that is not listed, or is not fixed by the corrective actions listed in the table, please contact Armasight's Customer Service center.

TABLE 4-2. OPERATOR TROUBLESHOOTING

MALFUNCTION	PROBABLE CAUSE/ TEST/INSPECTION	CORRECTIVE ACTION
Monocular fails to activate.	Battery is dead, missing or improperly installed.	Replace the battery or install it correctly.
	Battery contact surfaces or contact springs are dirty or corroded.	Clean the contact surfaces with a pencil eraser and/ or alcohol and cotton swabs.
	Defective image intensifier.	Please contact Customer Support.
Battery adapter difficult to remove.	Check for damaged battery adapter and battery cap.	If damaged please contact Customer Support.
IR illuminator fails to activate.	Turn the IR illuminator on in a dark area. Visually estimate whether or not the observed scene is illuminated.	If the IR illuminator fails to activate, please contact Customer Support.
LED indicators fail to activate.	Visual inspection.	Please contact Customer Support.
Poor image quality.	Check objective lens or eyepiece focus.	Refocus the lens.
	Check for fogging or dirt on the lens.	Clean the lens as detailed in Part 4.4.2. If image quality is still poor, please contact Customer Support.
	Damaged optical components.	Please contact Customer Support
Light is visible around the eyecup.	Check the exit pupil distance value.	Readjust for proper eye-relief distance.
	Check the eyecup resilience.	If the eyecup is defective, please contact Customer Support.
Focusing ring cannot be moved.	Check to see if the focusing ring is bent or broken.	If damaged, please contact Customer Support.
Eyepiece ring cannot be moved.	Check to see if the eyepiece ring is bent or broken.	If damaged, please contact Customer Support.

4.3 IDENTIFICATION OF OPERATIONAL DEFECTS

4.3.1 OPERATIONAL DEFECTS

Operational defects relate to the reliability of the intensifier, and are an indication of instability. If identified, the user will need to return the Avenger immediately. Operational defects include shading, edge glow, flashing, flickering, and intermittent operation.

A. Shading

If shading is persistent, you will not be able to see a fully circular image (Figure 4-1). Shading is a very dark, high-contrast area with a distinct line of demarcation present, and you cannot see an image through it. Shading always begins on the edge, and will eventually migrate inward until it spans across the entire image area. If you notice shading with your device, please contact Customer Support.

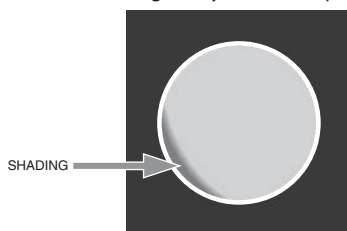

FIGURE 4-1. SHADING

NOTE:

Verify that any shading is not the result of improper eye-relief adjustment.

B. Edge Glow

Edge glow is a bright area (it sometimes appears to be sparkling) in the outer portion of the viewing area (see Figure 4-2). To check for edge glow, block out all light from the device by cupping a hand over the lens. If the image tube is displaying edge glow, the bright area will still show up; if edge glow occurs, please contact Customer Support.

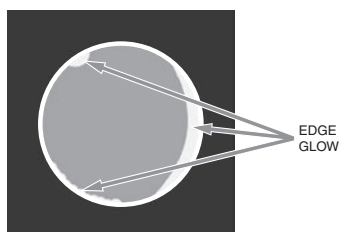

FIGURE 4-2. EDGE GLOW

C. Flashing, Flickering, or Intermittent Operation

The image may appear to flicker or flash. If there is more than a single flicker, check for a loose battery adapter or a weak battery. If flickering continues, please contact Customer Support.

4.3.2 COSMETIC BLEMISHES

Cosmetic blemishes are usually the result of manufacturing imperfections. They **do not** affect the reliability of the image intensifier, and are not normally a cause for returning the Avenger. However, some types of cosmetic blemishes can worsen over time and interfere with the user's ability to properly oper-

ate the device during missions. If you believe a cosmetic blemish is cause for returning the device, record the specific nature of the problem on the maintenance forms and use the clock method to identify the position of the blemish and its approximate distance from the center (e.g., 5:00 toward the outside, 2:30 near the center, or 1:00 midway).

The following are examples of cosmetic blemishes:

A. Bright Spots

A bright spot is a small, non-uniform bright area that may flicker or appear constant (Figure 4-3).

Not all bright spots make the Avenger rejectable. Cup your hand over the lens to block out all light. If the bright spot remains please contact Customer Support.

Bright spots usually go away when all light is blocked out. Verify that any bright spots are not simply the result of bright light in the area you are observing. Bright spots are acceptable if they do not interfere with the user's ability to view the scene or perform missions.

B. Emission points

Emission points are steady or fluctuating pinpoint of bright light in the image area that do not go away when all external light is blocked from the objective lens (Figure 4-3). The position of an emission point within the image area does not move. Not all emission points are cause to return the Avenger. Verify that emission points are not simply light sources present in the scene you are observing. Emission points are acceptable if they do not interfere with the user's ability to perform missions.

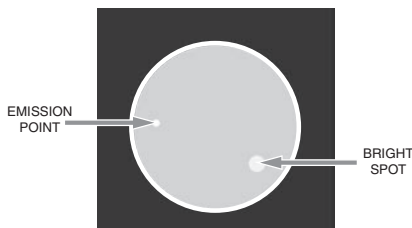

FIGURE 4-3. EMISSION POINTS AND BRIGHT SPOTS

C. Black Spots

Black spots are cosmetic blemishes in the image intensifier or debris between the lenses. Black spots are acceptable as long as they do not interfere with the user's ability to observe the scene. No action is required if this condition is present, unless the spots interfere with the operator's ability to perform missions.

D. Fixed-Pattern Noise

Fixed-pattern noise is usually a cosmetic blemish characterized by a faint hexagonal (honeycomb) pattern that appears throughout the viewing area. This typically occurs in excessively lit environments or when viewing very bright lights (See Figure 4-4). This pattern can be seen in every image intensifier if the level of light is high enough. This condition is acceptable as long as the pattern does not interfere with the user's ability to view an image or interfere with their ability to perform missions.

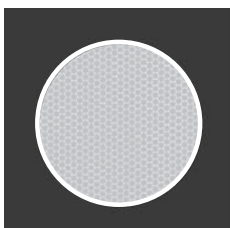

FIGURE 4-4. FIXED-PATTERN NOISE

E. Chicken Wire

Chicken wire is an irregular pattern of dark thin lines that can appear in the field of view, either throughout the image area or in sections of the image area (See Figure 4-5). In the worst-case scenario, these lines will form hexagonal or square-wave shaped lines. No action is required if this condition is present, unless it interferes with the user's ability to view the image or their ability to perform missions.

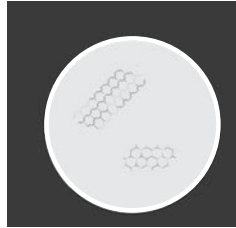

FIGURE 4-5. CHICKEN WIRE

4.4 MAINTENANCE

4.4.1 GENERAL

The section regarding Avenger operator maintenance consists of operational tests, inspections for the unit serviceability, cleaning and mounting procedures, troubleshooting, and replacement instructions for a limited number of parts. Maintenance instructions covered elsewhere in this manual (PMCS, troubleshooting, etc.) are not repeated in this section.

CAUTION:

The Avenger is a precision electron-optical instrument, and must be handled carefully at all times to prevent damage to the device's body or mechanisms.

4.4.2 CLEANING PROCEDURES

CAUTION:

The coating on the demist shield can be damaged if the shield is cleaned while wet, or if it is cleaned with wet lens paper. Clean the shield only when it is dry, and only use dry lens paper.

CAUTION:

Thoroughly dry each item before placing them into the storage case.

Clean the Avenger as follows:

1. Gently brush off any dirt from the unit's body using a clean, soft cloth.
2. Moisten the cloth with fresh water and gently wipe external surfaces (**except** for glass surfaces).
3. Dry any wet surfaces (**except** for glass surfaces) with another clean, soft, dry cloth.
4. Using a lens brush, carefully remove all loose dirt from the glass surfaces.
5. Slightly dampen a cotton swab with ethanol. Gently and slowly wipe the lenses (including the photoreceiver and the pivotal focusing lens). Without touching the lens holders, clean the glass surfaces

in circular movements, beginning in the center and moving out towards the edge. Change the cotton swab after each circular stroke. Repeat until the glass surfaces are clean.

6. Clean the battery contact surfaces and contact springs with a pencil eraser and/ or alcohol-dampened cotton swabs.

Clean optional mounting devices with a soft brush (cloth), soap, and water as required.

Clean optional lenses as detailed in items 4 and 5 above (**except** for the demist shield).

4.4.3 BATTERY REMOVAL AND REPLACEMENT

Refer to Part 3.1.1 for battery installation procedures. No special tools are required to replace the battery.

4.5 RETURN INSTRUCTIONS

For service, repair or replacements, please email service@armasight.com.

To assist the Service Representative (SR) with determining if the item is repairable, please provide the following information:

1. Serial Number of the defective item.
2. Thorough description of the malfunction, defect or damage.
3. An explanation of how the malfunction, defect or damage occurred, if known.

If the SR determines that the item is under warranty or should be returned for repair, a Return Material Authorization number (RMA#) will be provided. RMA can be obtained via e-mail to service@armasight.com or via phone by calling Armasight Customer Service at (888)959-2259 Ext. 2 or via fax (888)959-2260.

When returning the Avenger for service or repair, the following procedures should be followed to prevent any additional damage:

1. Verify that the Avenger is free of all contaminants such as dirt or any other foreign material.
2. Remove the battery.
3. Place the cap over the lens.
4. Place the Avenger in the hard shipping/ storage case or soft carrying case (if available). If the hard shipping/ storage case is not available, individually package each Avenger unit being returned in a suitable container.

Place the Avenger and a copy of the test report or detailed description of the failure in a suitable packing/ shipping container. Mark the package with the RMA#. Ship the items using the fastest, most easily traceable, prepaid method to Armasight Inc., 815 Dubuque Avenue, South San Francisco, CA 94080, USA.

A. AVENGER LIST OF SPARE PARTS

The parts authorized in this list of spare parts are required for operator maintenance. This list includes parts that must be removed in order to replace authorized parts.

ITEM NO. Column indicates the number used to identify items in Figure A-1.

PART NO. Column indicates the primary number used by the manufacturer to identify an item; this number controls the design and characteristics of the item by means of its engineering, specifications, standards, and inspection requirements.

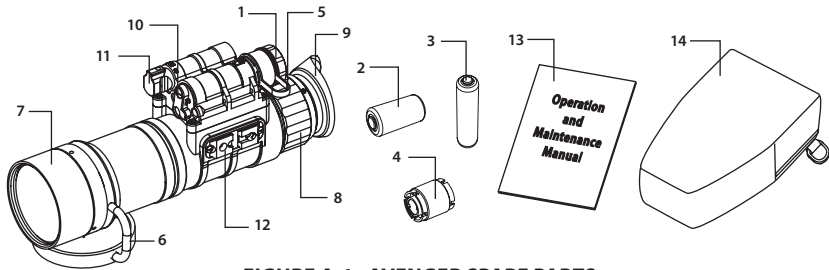

FIGURE A-1. AVENGER SPARE PARTS

TABLE A-1. AVENGER LIST OF SPARE PARTS

ITEM NO.	DESCRIPTION	PART NO.
1.	Battery Cap	AVENG3XBC
2.	CR123A Lithium Battery	ALT
3.	AA Alkaline Battery	ALT
4.	Battery Adapter	AVENG3XBA
5.	Battery Cap Retainer	AVENG3XBCR
6.	Lens Cap	AVENG3XLC
7.	Objective Lens Assembly	AVENG3XOLA
8.	Eyepiece Assembly	AVENG3XEPA
9.	Eyecup Assembly	AVENG3XECA
10.	Pivotal Focusing Lens	AVENG3XPFL
11.	Turn-pull Function Switch	AVENG3XFS
12.	Rail	AVENG3XPR
13.	Operation and Maintenance Manual	AVENG3XOUMM
14.	Soft Carrying Case	AVENG3XSCC
15.	Shipping/Storage Case	AVENG3XSSC

B. PRODUCT WARRANTY REGISTRATION CARD

In order to validate the warranty on your product, Armasight must receive a completed Product Warranty Registration Card for each unit, or the user must complete warranty registration on our website (www.armsight.com). Please complete the included form and immediately mail it to our Service Center: Armasight Inc., 815 Dubuque Avenue, South San Francisco, CA 94080, USA

ARMASIGHT PRODUCT WARRANTY REGISTRATION CARD

PRODUCT INFORMATION

Product Name _____ Purchased From _____

Purchase Date _____ Product Serial # _____

CUSTOMER INFORMATION

Name _____

Address _____

City _____ Country _____ Zip _____

Day Phone # _____ Home Phone # _____

E-mail address _____

.....
Customer Signature Required

ALPHABETICAL INDEX

A

Abbreviations 10

B

Battery Installation 17

Black Spots 28

Bright Spots 28

C

Cautions 2

Chicken Wire 29

Cleaning 29

Continuous Operation 13

Cosmetic Blemishes 27

D

Dimensions 13

Diopter Adjustment 13, 21

E

Edge Glow 27

Emission Points 28

Eye Relief 13

F

Fixed-Pattern Noise 28

Flashing, Flickering, or Intermittent Operation 27

F-number 13

Function Switch 12, 21

G

General Information 7

I

IR Illumination Range 13

IR Illuminator 12, 15, 22

M

Magnification 13

Maintenance 24, 29

- Preventive 24

Mounting 17

O

Objective Lens Focus 21, 28

Operating Instructions 20

Operational Defects 27

Operator Troubleshooting 26

P

PMCS 24

Preparations for Storage 23

S

Safety Summary 2

Shading 27

Spare Parts 31

System Description 11

W

Warranty Information 8

Weight 13



Armasight Inc.

815 Dubuque Avenue
South San Francisco
CA 94080, USA

Phone: (888)959-2259

Fax: (888)959-2260

Intl Phone/Fax: (650)492-7755

info@armasight.com

 **WARNING:**

This product contains natural rubber latex which may cause allergic reactions! The FDA has noted an increase in the number of reported deaths that are associated with an apparent sensitivity to natural latex proteins. If you are allergic to latex, it is a good idea to learn which products contain it and strictly avoid exposure to those products.

www.armasight.com