

Instruction Manual

LX70 Series

German Equatorial

Telescopes





WARNING!



Never use a Meade® LX70™ Telescope to look at the Sun!

Looking at or near the Sun will cause instant and irreversible damage to your eye. Eye damage is often painless, so there is no warning to the observer that damage has occurred until it is too late. Do not point the telescope at or near the Sun. Children should always have adult supervision while observing.

© The name "Meade" and the Meade logo are trademarks registered with the U.S. Patent and Trademark Office and in principal countries throughout the world.

Protected by U.S. Patent: US 6,392,799 and other Patents Pending
© 2014 Meade Instruments Corp.

Table of Contents

LX70 Key Features	4
Getting Started	7
Unpacking and Assembly	7
Balancing the Telescope	10
Aligning the Viewfinder	11
Choosing an Eyepiece	12
Using the Bubble Level	12
Observing by Moving the Telescope Manually	12
Observe the Moon	13
Tracking Objects	13
Locating the Celestial Pole	14
General Maintenance	15
Inspecting the Optics	15
Collimating the Newtonian Reflector	16
Optional Accessories	18
Appendix A: Celestial Coordinates	19
Appendix B: Setting Circles	20
Appendix C: Latitude Chart	21
Appendix D: Basic Astronomy	22
Meade Customer Service	24
Meade Warranty	24

LX70 Mount Key Features

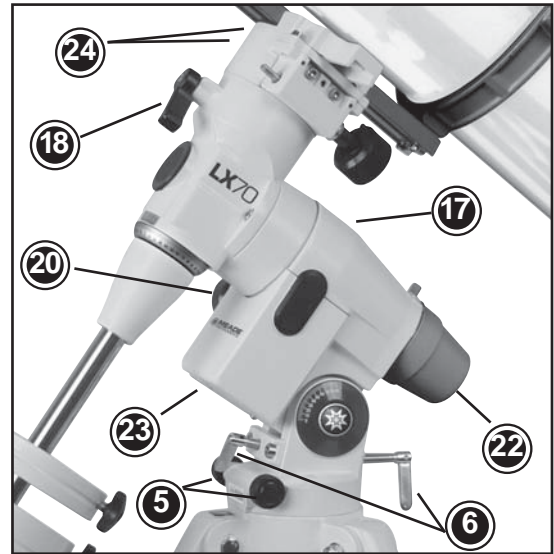
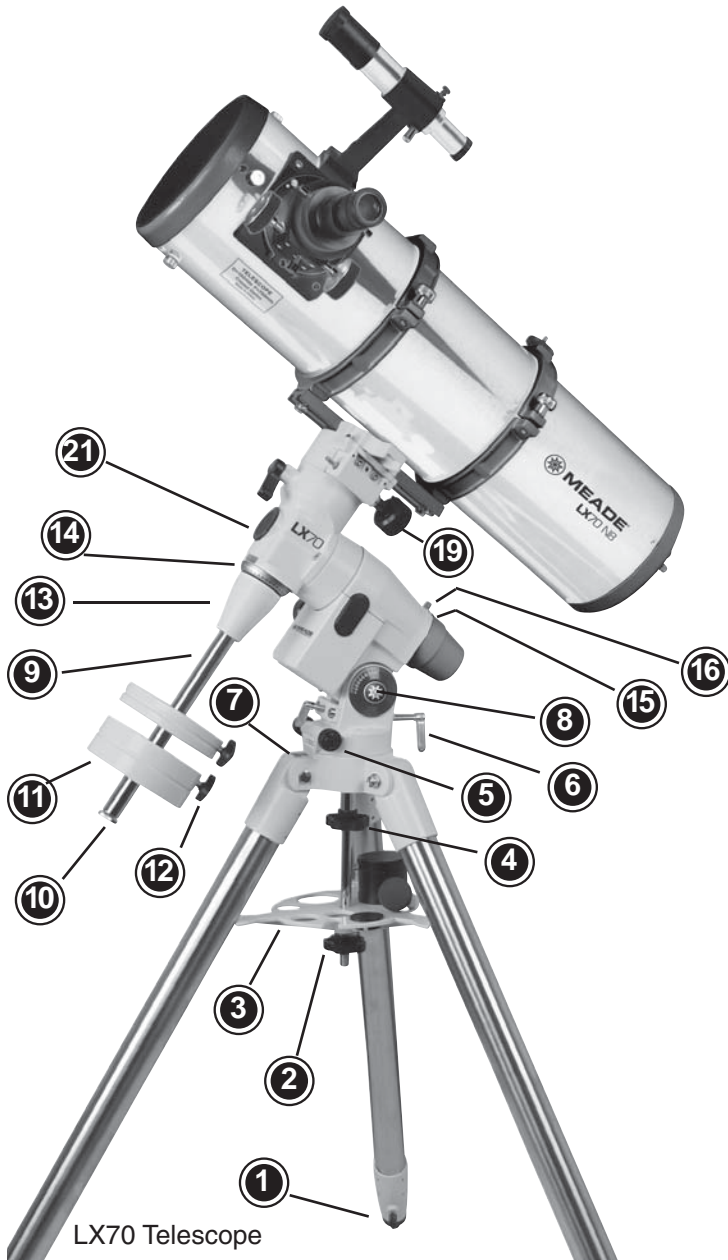

Mount Close-up

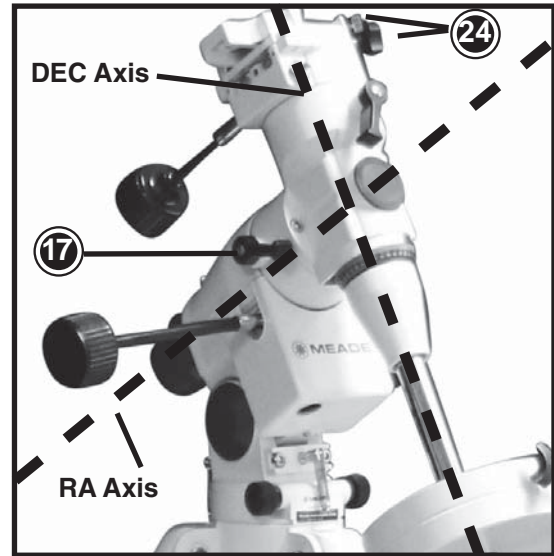

RA & DEC Axes

- | | |
|----------------------------------|---|
| ① Tripod Leg Lock Knob | ⑬ Counterweight Shaft Locking Nut |
| ② Tripod Spreader Lock Knob | ⑭ DEC Setting Circle |
| ③ Tripod Spreader | ⑮ RA Setting Circle (not shown) |
| ④ Mount Locking Knob and Shaft | ⑯ RA Setting Circle Locking Knob |
| ⑤ Azimuth Adjustment Knob | ⑰ RA Clutch Locking Knob (see inset) |
| ⑥ Latitude Adjustment Knob | ⑱ DEC Clutch Locking Knob |
| ⑦ North Tripod Leg | ⑲ DEC Slow Motion Control Knob |
| ⑧ Latitude Scale | ⑳ RA Slow Motion Control Knob |
| ⑨ Counterweight Shaft | ㉑ Polar Scope Front Cap |
| ⑩ Counterweight Shaft Safety Nut | ㉒ Polar Scope Rear Cap |
| ⑪ Counterweight | ㉓ R.A. Motor Cover(R.A. motor not included) |
| ⑫ Counterweight Locking Knob | ㉔ OTA Dovetail Lock Knobs(see inset) |

Figure 1: LX70 Key Features

LX70 OTA Key Features

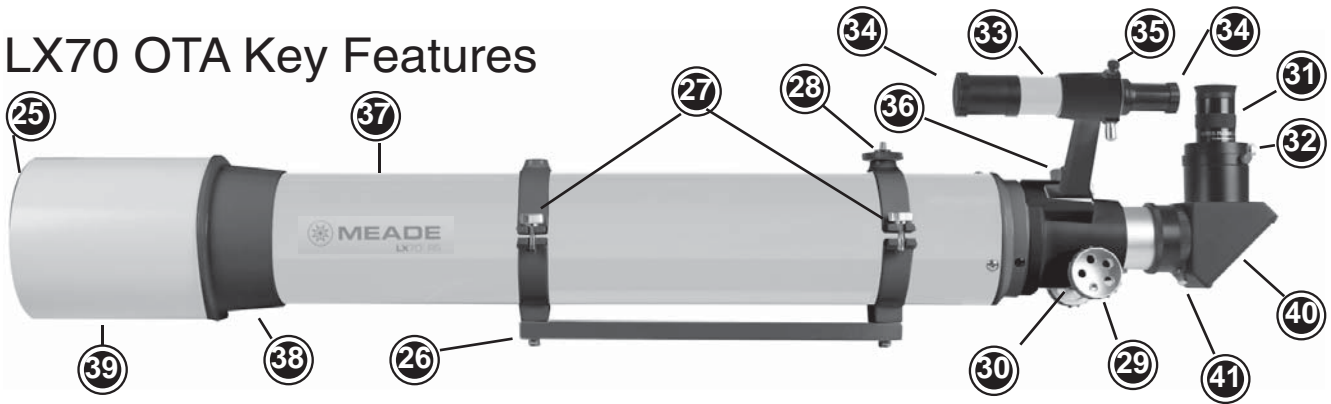

- | | | | |
|----|---|----|-----------------------------------|
| 25 | Front Dust Cover (not shown) | 34 | Viewfinder Dust Caps |
| 26 | Dovetail Rail | 35 | Viewfinder Adjustment Screws |
| 27 | Cradle Ring & Cradle Ring Lock Knobs | 36 | Viewfinder Bracket with Lock Knob |
| 28 | 1/4-20 Accessory Mounting Screw with Lock | 37 | Optical Tube Assembly (OTA) |
| 29 | Focuser and Focuser Wheel | 38 | Objective Lens Cell |
| 30 | Focuser Lock Knob | 39 | Dewshield |
| 31 | Eyepiece | 40 | Diagonal Mirror |
| 32 | Eyepiece Holder Thumbscrews | 41 | Diagonal Mirror Thumbscrews |
| 33 | Viewfinder | | |

Figure 2: LX70 Refractor Optical Tube

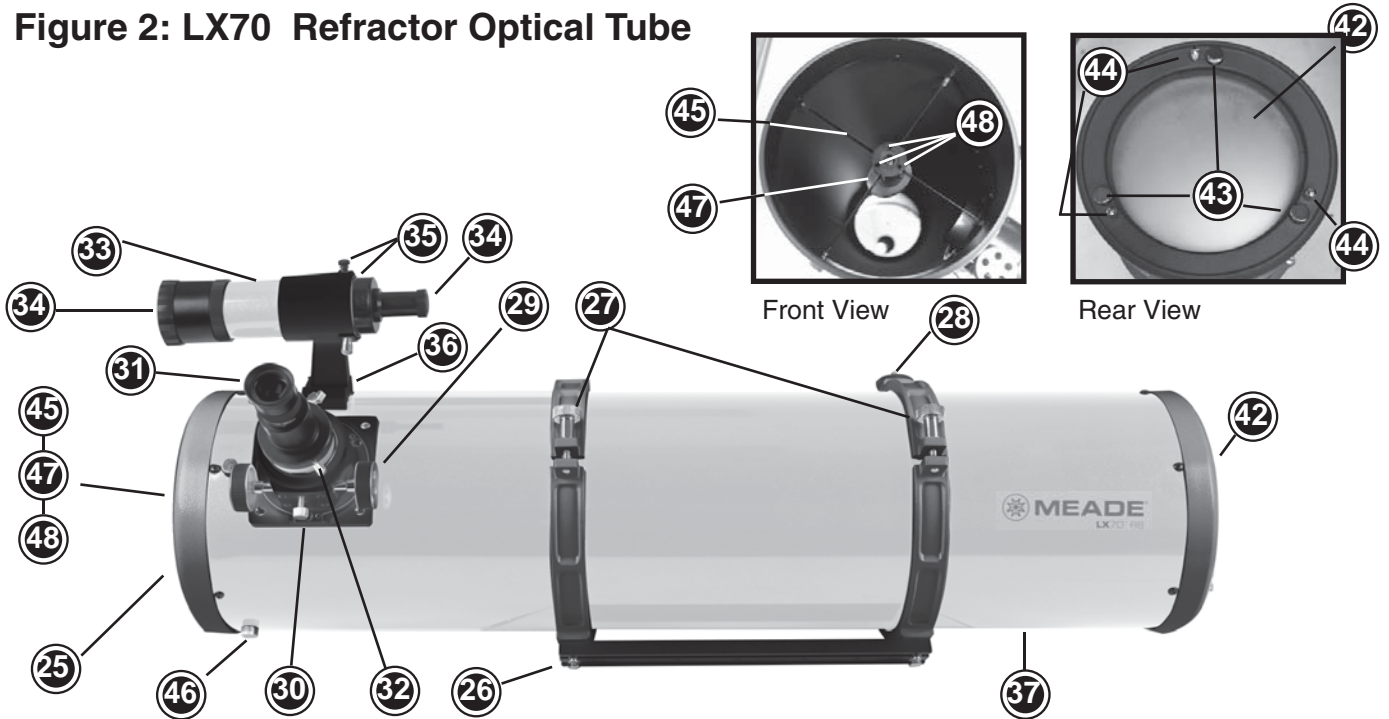

- | | | | |
|----|---|----|---|
| 25 | Front Dust Cover (not shown) | 35 | Viewfinder Adjustment Screws |
| 26 | Dovetail Rail | 36 | Viewfinder Bracket with Lock Knob |
| 27 | Cradle Ring & Cradle Ring Lock Knobs | 37 | Optical Tube Assembly (OTA) |
| 28 | 1/4-20 Accessory Mounting Screw with Lock | 42 | Primary Mirror (see inset) |
| 29 | Focuser & Focuser Wheel | 43 | Primary Mirror Collimation Adjustment Knobs |
| 30 | Focuser Lock Knob | 44 | Primary Mirror Collimation Lock Knobs |
| 31 | Eyepiece | 45 | Spider Vane (see inset) |
| 32 | Eyepiece Holder Thumbscrews | 46 | Spider Vane Tension Knobs |
| 33 | Viewfinder | 47 | Secondary Mirror (see inset) |
| 34 | Viewfinder Dust Caps | 48 | Secondary Mirror Collimation Screws (see inset) |

Figure 3: LX70 Reflector Optical Tube

LX70 OTA Key Features

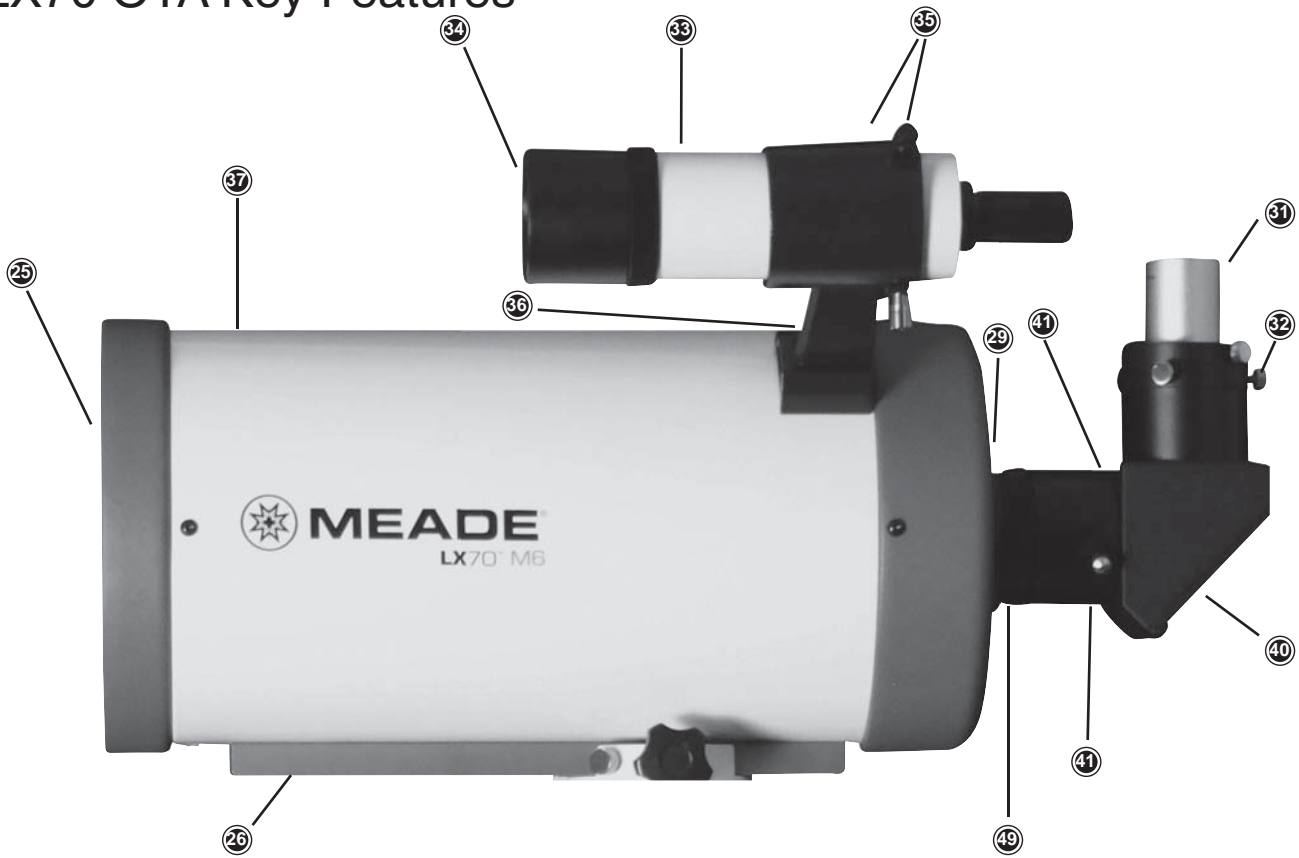

- | | |
|---------------------------------|--------------------------------------|
| ②⑤ Front Dust Cover (not shown) | ③⑤ Viewfinder Adjustment Screws |
| ②⑥ Dovetail Rail | ③⑥ Viewfinder Bracket with Lock Knob |
| ②⑨ Focuser Knob (not shown) | ③⑦ Optical Tube Assembly (OTA) |
| ③① Eyepiece | ④① Diagonal Mirror |
| ③② Eyepiece Holder Thumbscrews | ④① Diagonal Mirror Thumbscrews |
| ③③ Viewfinder | ④⑨ Extension Tube |
| ③④ Viewfinder Dust Caps | |

Figure 4: LX70 Maksutov Optical Tube

Getting Started

The Meade LX70 series models are versatile, high-resolution telescopes. They offer unmatched mechanical and optical performance that reveal nature in an ever-expanding level of detail. Observe the feather structure of an eagle from 50 yards or study the rings of the planet Saturn from a distance of 800 million miles. Focus beyond the Solar System and observe majestic nebulae, ancient star clusters, and remote galaxies.

Meade LX70 series telescopes are instruments fully capable of growing with your interest and can meet the requirements of the most demanding advanced observer. Before using your telescope, read the entire instructions carefully. Your telescope should be assembled during daylight hours and setup in an area that allows you to unpack all the included parts.

Unpacking and Assembly

1. Remove the components from the boxes: Remove and identify the telescope's equipment. Refer to FIG. 1 - 4 for images of the parts and the overall assembly of your telescope.

When removing the tripod from the box, hold the assembly parallel (horizontal) to the ground or the inner tripod leg extensions may slide out if they are not locked in place. Tighten the tripod leg lock knobs (Fig. 1. #1) to secure the legs in place.

2. Adjust the tripod legs: Spread the tripod legs as far apart as they will open. Now adjust the individual tripod legs by loosening the tripod leg lock knobs and extending the inner legs until the tripod head is approximately level to the ground. Relock the leg lock knob until firm.

3. Attach the spreader bar to the tripod: Thread the small end of the Mount Locking Knob and Shaft (Fig. 1, #4) along with the washer all the way into the bottom of the tripod head. When complete, the shaft will be held captive and allowed to be raised above the threads.

Next, remove the Tripod Spreader Lock Knob (Fig. 1, #2) and washer. Place the center hole of the Tripod Spreader (Fig. 1, #3) onto the chrome

shaft with the flat side facing up. Loosely thread on the Tripod Spreader Lock Knob and washer



Figure 5: Installing the mount locking knob and shaft

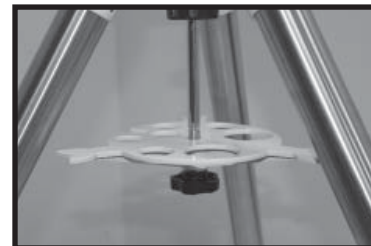

Figure 6: Tripod spreader

to prevent the tripod spreader from falling off the shaft.

4. Attach mount to tripod: Place the LX70 mount onto the tripod head with the protrusion on top of the tripod's head positioned between the fine azimuth adjustment knobs (Fig 1, #5). If necessary, back off the azimuth adjustment knobs wide enough for the protrusion to fit between them.

Next, tighten the Mount Locking Knob (Fig. 1, #4) so the mount secures to the tripod head. Tighten this knob to a firm feel. Then rotate the Tripod Spreader (Fig. 1, #3) so the wings of the spreader align with each tripod leg. Tighten the Tripod Spreader Lock Knob (Fig. 1, #2) until firm. When you wish to collapse the tripod, loosen the Tripod Spreader Lock Knob and rotate the wings so they are between the tripod legs. You do not need to remove the Tripod Spreader unless desired.



Figure 7: Attaching mount to tripod



Figure 8: Tightening the spreader lock knob

5. **Attach the counterweight shaft:** Locate the counterweight shaft (Fig. 1, #9) and thread down the Locking Nut (Fig. 1, #13) until it stops. Next, thread the counterweight shaft into the threaded hole on the front side of the mount,

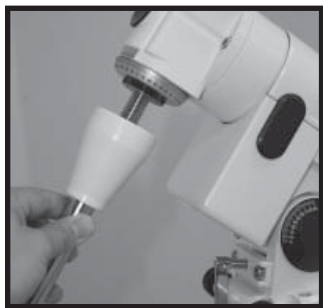

Figure 9: Attach the counterweight shaft



Figure 10: Set the latitude

below the declination setting circle (Fig. 1, #14). Tighten to a firm feel. Adjust the Locking Nut upward toward the mount until it stops. Tighten to a firm feel.

6. **Install the latitude adjusting screws:** Locate the two threaded latitude knobs (Fig. 1, #6) in the box. Thread the longer latitude adjustment knob into the rear of the mount and the shorter latitude adjustment knob into the front of the mount as shown.

7. **Set the latitude:** Setting the latitude is easier if it is set before you attach the optical tube and counterweights. Locate the latitude dial (Fig. 1, #8); note that there is a triangular pointer above the dial located on the mount. The pointer is not fixed; it moves as the mount moves.

Determine the latitude of your observing location. See **APPENDIX C: LATITUDE CHART** for a list of latitudes, or check the internet. Move the latitude screws in order to move the mount until the pointer points to your latitude. The two latitude screws work in a “push - pull” operation—as you tighten one, loosen the other.



Figure 11: Latitude pointer



Figure 12: North tripod leg

When the pointer points at your latitude, tighten both screws until they make contact with the mount. At your observing site, set up the telescope assembly so that the tripod leg below the counterweight shaft, labeled “N”, (FIG. 1, #7) approximately faces True North (or True South in the Southern Hemisphere). For more information see page 14 **LOCATING THE CELESTIAL POLE.**

8. **Attach the slow motion control cables:** The LX70 comes equipped with flexible slow motion control cables for both the RA & Dec axes. Each cable is securely fastened on each axis by a small Phillips head screw. Locate the RA worm shaft mounting location and notice that it has a flat portion on one side (see Fig 13). Slide one of the cables onto the shaft so the Phillips head locking screw is aligned with the flat portion on the shaft. Using the included Phillips screw driver, secure the slow motion control cable onto the shaft until firm. Repeat this process for the declination cable (see Fig 14).

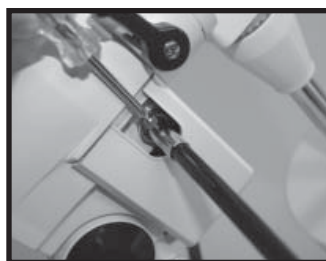

Figure 13: Attach the RA slow motion control cable

Figure 14: Attach the DEC slow motion control cable



9. **Attach the counterweight(s):** Look through the hole in the counterweight (Fig. 1, #11) and note the pin blocking the hole. Loosen the coun-



Figure 15: Remove the safety nut



Figure 16: Install the counterweight

terweight lock knob so the pin is not obstructing the hole. Unscrew the safety cap (Fig. 1, #10) from the shaft. Holding the counterweight firmly in one hand, slip the counterweight to approximately the midpoint of the counterweight shaft. Tighten the counterweight lock knob (Fig. 1, #12) to a firm feel. Replace the safety cap.

Note: If the counterweight ever slips, the safety cap prevents the counterweight from sliding entirely off the shaft. Always leave the safety cap in place when the counterweight is on the shaft.

10. Attach the optical tube: Before attaching the optical tube, lock both the RA and DEC axes (Fig. 1, #17 & 18) so the mount does not move during installation. Verify the cradle ring lock knobs (Fig. 2 or 3, #27) are tight and securely fastened to the OTA. The cradle rings should be roughly centered on the OTA during installation. While firmly holding the optical tube with both hands, slide the cradle assembly onto the cradle mounting slot at the top of the mount (see Fig 17).

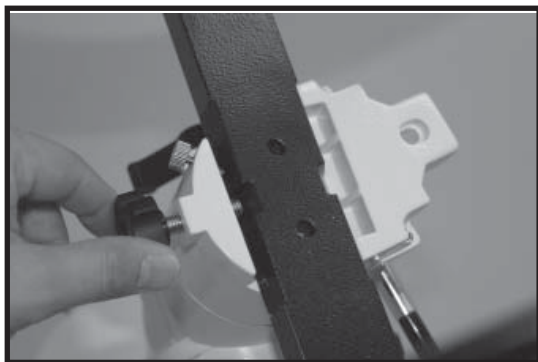

Figure 17: Tightening the dovetail lock knobs

Tighten both OTA dovetail lock knobs (Fig. 1, #24) onto the dovetail rail (Fig. 2 - 4, #26) to a firm feel. The cradle rings and OTA will now be securely fastened to the mount.

After attaching all accessories to the OTA, you



Figure 18: Viewfinder parts

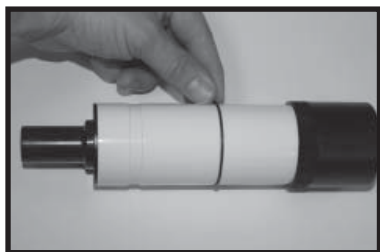

Figure 19: Installing the viewfinder o-ring

will need to balance the telescope before use. See the section **BALANCING THE TELESCOPE**.

11. Assemble the viewfinder: Locate the viewfinder bracket. Carefully remove the rubber O-ring from the bracket and position the O-ring into the groove located approximately half-way down the viewfinder tube (see Fig 18 & 19). Unscrew the black alignment screws on the bracket and slide the viewfinder optical tube until the O-ring seats into the bracket. One alignment screw on the bracket is spring loaded to allow easier alignment of the viewfinder. Pull out on the spring loaded alignment screw to retract it, allowing the viewfinder tube to fit properly into the bracket. When the O-ring is properly seated in the bracket, tighten the two alignment screws to secure the viewfinder in place.



Figure 20: Attaching the viewfinder bracket

12. Attach viewfinder bracket: Slide the viewfinder bracket into its receiver on the OTA (Fig. 2 - 4, #36). To secure the viewfinder to the telescope, tighten the viewfinder bracket lock knob to a firm feel.

13. Insert the eyepiece:

Newtonian Reflector Models only (Fig 3): Lift to remove the dust cap from the eyepiece holder on the focuser assembly (Fig 3, #30). Set the dust cap aside in a safe place and replace it



Figure 21: Insert the 26mm eyepiece

when you have finished observing. Back off the eyepiece thumbscrews (Fig 3, #32) and insert the supplied eyepiece(Fig 3. #31) into the eyepiece holder. Tighten the holder thumbscrews to a firm feel to secure the eyepiece.

Note: Some models require an extension tube (if included) be used to reach focus.

Achromatic Refractor only (Fig 2): Lift to remove the dust cap from the eyepiece holder on the focuser assembly(Fig 2, # 30). Set the dust cap aside in a safe place and replace it when you have finished observing. Back off the eyepiece thumbscrews (Fig. 2, #41) and slide the diagonal(Fig. 2, #40) into the holder tightening the thumbscrews to a firm feel only. Insert the supplied 26mm eyepiece(Fig. 2, #31) into the diagonal. Tighten the eyepiece holder thumbscrews (Fig. 2, #32) to a firm feel to secure the eyepiece.

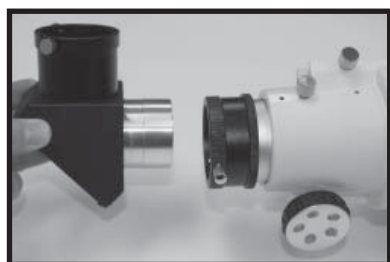

Figure 22: Attach the diagonal



Figure 23: Insert the eyepiece

Maksutov Models only (Fig 4): Lift to remove the dust cap from the extension tube (Fig 4, # 49). Set the dust cap aside in a safe place and replace it when you have finished observing. Back off the diagonal mirror thumbscrews (Fig. 4, #41) and slide the diagonal(Fig. 4, #40) into the holder and tighten the thumbscrews to a firm feel only. Insert the supplied eyepiece(Fig.



Figure 24: Attach the diagonal



Figure 25: Insert the eyepiece

4, #31) into the diagonal mirror. Tighten the eyepiece holder thumbscrews(Fig. 4, #32) to a firm feel to secure the eyepiece.

Balancing the Telescope

In order for the telescope to be stable on the tripod and for it to move smoothly, it must be balanced. To balance the telescope, unlock the Right Ascension or R.A. lock (Fig 1, #17). When this axis is unlocked, the telescope pivots on the R.A. axis(see Fig. 1 inset). Later in the procedure, you will also unlock the Declination or Dec. lock (Fig. 1, #18).When unlocked, the telescope pivots on the Dec. axis (see Fig 1 inset). Most of the motion of the telescope takes place by moving about these two axes, separately or simultaneously. Try to become familiar with these locks and observe how the telescope moves on each axis. To obtain a fine balance of the telescope, follow the following method:

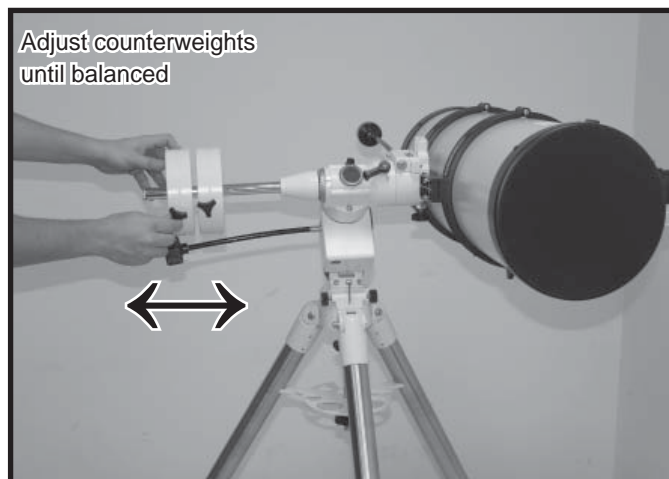

Figure 26: Balancing the RA axis

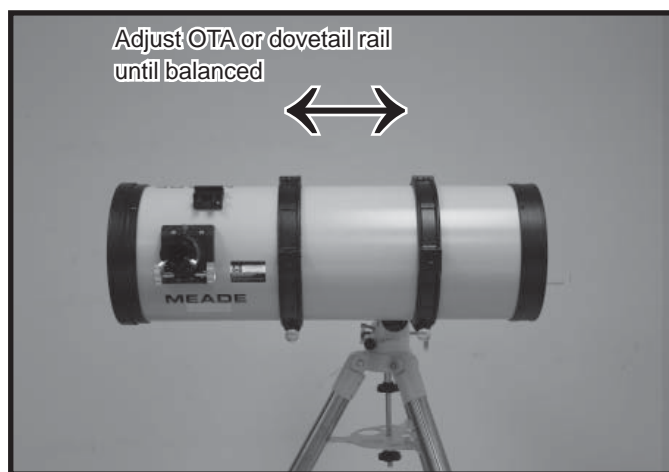

Figure 27: Balancing the DEC axis.

1. Firmly hold the counterweight shaft secure so it cannot swing freely. Loosen the R.A. lock (Fig. 1, #17). The optical tube now moves freely about the R.A. axis. Rotate the telescope so that the counterweight shaft (Fig. 1, #9) is parallel (horizontal) to the ground (see Fig. #26).

2. Unlock the counterweight lock knob and slide the counterweight along the counterweight shaft until the telescope remains in one position without tending to drift down in either direction about the RA axis. Then re-tighten the counterweight lock knob, locking the counterweight securely in position.

Now, hold the optical tube so that it cannot swing freely. Lock the R.A. lock and while holding the OTA in place, unlock the Dec. lock (Fig. 1, #18). The OTA is now able to move freely about the Dec. axis. Lightly loosen the cradle ring lock knobs (Fig. 2 - 4, #27) so that the main tube slides easily back and forth in the cradle rings. Do not loosen the cradle ring lock knobs too much or the OTA can slip out of the cradle rings.

Move the main tube in the cradle rings until the telescope remains in one position without tending to drift down in either direction. Re-lock the Dec. lock (Fig. 2 - 4, #27).

The telescope is now properly balanced on both axes. Next, the viewfinder must be aligned.

Aligning the Viewfinder

NEVER point the telescope directly at or near the Sun at any time! Observing the Sun, even for the smallest fraction of a second, will result in instant and irreversible eye damage, as well as physical damage to the telescope itself.

The wide field of view of the telescope's viewfinder (Fig. 2 - 4, #33) provides an easier way to initially sight objects than the main telescope's eyepiece, which has a much narrower field of view. If you have not already attached the viewfinder to the telescope tube assembly, see the section **UNPACKING AND ASSEMBLY**.

In order for the viewfinder to be useful, it must be aligned to the main telescope, so both the viewfinder and telescope's optical tube point at the same position in the sky. This alignment makes it easier to find objects: First locate an object in

the wide-field viewfinder, then look into the eyepiece of the main telescope for a detailed view. To align the viewfinder, perform steps 1 through 7 during the daytime; perform step 8 at night.

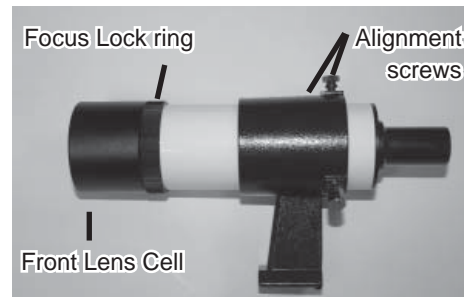

Figure 28: Viewfinder adjustments

1. Remove the dust covers from the optical tube and the viewfinder.

2. If you have not already done so, insert the low-power 26mm eyepiece into the eyepiece holder or diagonal of the main telescope.

3. Look through the viewfinder eyepiece at an object at least 200 yards away.

4. If the distant object is not in focus, turn the focus lock ring on the front of the viewfinder counterclockwise to loosen the viewfinder front lens cell (see Fig. 28). Twist the front cell until focus is achieved and retighten the focus lock ring.

5. Unlock the R.A. and Dec locks so the telescope turns freely on both axes. Then point the main telescope at a tall, well defined and stationary land object (e.g., the top of a telephone pole) at least 200 yards distant and center the object in the telescope's eyepiece.

6. Focus the image by turning the OTA focus knobs (Fig. 2 - 4, #29). Retighten the R.A. and Dec. locks.

7. Look through the viewfinder and loosen or tighten, as appropriate, one or both of the viewfinder alignment thumbscrews (Fig. 2 - 4, #35) until the viewfinder's crosshairs are precisely centered on the object you previously centered in the main telescope's eyepiece. You are now ready to make your first observations with your telescope!

8. Check this alignment on a celestial object, such as a bright star or the Moon, and make any necessary refinements, using the method

outlined above. With this alignment performed, objects first located in the wide-field viewfinder will also appear in the telescope's eyepiece.

Choosing an Eyepiece

A telescope's eyepiece magnifies the image formed by the telescope's main optics. Each eyepiece has a focal length, expressed in millimeters, or "mm." The smaller the focal length, the higher the magnification. For example, an eyepiece with a focal length of 9mm has a higher magnification than an eyepiece with a focal length of 26mm. Your telescope comes supplied with a 26mm eyepiece which gives a wide, comfortable field of view with high image resolution.

Low power eyepieces offer a wide field of view, bright, high-contrast images, and eye relief during long observing sessions. To find an object with a telescope, always start with a lower power eyepiece such as the 26mm. When the object is located and centered in the eyepiece, you may wish to switch to a higher power eyepiece to enlarge the image as much as practical for prevailing seeing conditions. For information about optional eyepieces for the LX70 Series models, see **OPTIONAL ACCESSORIES**.

The power, or magnification of a telescope is determined by the focal length of the telescope and the focal length of the eyepiece being used. To calculate eyepiece power, divide the telescope's focal length by the eyepiece's focal length.

For example, a 26mm eyepiece is supplied with the LX70 series. The focal length of the 8" reflector model is 1000mm.

Telescope Focal Length ÷ Eyepiece Focal Length = Magnification (Power)
Telescope Focal Length = 1000mm
Eyepiece Focal Length = 26mm
 $1000 \div 26 = 38.46$

The eyepiece power, or magnification is therefore 38X (approximately).

Can you ever have too much power? If the type of power you're referring to is eyepiece magnification, yes, you can! The most common mistake of the beginning observer is to "overpower" a telescope by using high magnifications which the telescope's aperture and atmospheric con-

ditions cannot reasonably support. Keep in mind that a smaller, but bright and well-resolved image is far superior to one that is larger, but dim and poorly resolved.

Powers above 400X should be employed only under the steadiest atmospheric conditions. Most observers will eventually want three or four additional eyepieces to achieve the full range of reasonable magnifications possible with the LX70 telescopes. See **OPTIONAL ACCESSORIES**.

Using the Bubble Level

For best telescope performance, the equatorial mount should be properly leveled. A level tripod allows better weight distribution and easier alignment on the night sky. The LX70 mount includes a small bubble level near its base. Adjust the height of each tripod leg until the bubble appears in the center of the circle.

Note: Adjusting the tripod on a fully assembled mount can be dangerous. Get the assistance of a friend if attempting to adjust the tripod height while fully assembled.

Observing by Moving the Telescope Manually

After the telescope is assembled and balanced as described previously, you are ready to begin manual observations. View easy-to-find terrestrial objects such as street signs or traffic lights to become accustomed to the functions and operations of the telescope. For the best results during observations, follow the suggestions below:

When you wish to locate an object to observe, first loosen the telescope's R.A. lock and Dec. lock. The telescope can now turn freely on its axes. Unlock each axis separately and practice moving your telescope. Then practice with two unlocked axes at the same time. It is very important to practice this step to understand how your telescope moves, as the movement of an equatorial mount is not intuitive.

Use the aligned viewfinder (see **ALIGNING THE VIEWFINDER**, pg 11) to sight-in on the object you wish to observe. When the object is centered in the viewfinder's crosshairs, re-tight-

en the R.A. and Dec. locks.

Once centered, an object can be focused by turning one of the knobs of the focusing mechanism. Notice that when observing astronomical objects, the field of view begins to slowly drift across the eyepiece field. This motion is caused by the rotation of the Earth on its axis. Objects appear to move through the field more rapidly at higher powers. See **TRACKING OBJECTS** for detailed information on how you can counteract the drift in the field of view.

Observe the Moon

Point your telescope at the Moon (note that the Moon is not visible every night). The Moon contains many interesting features, including craters, mountain ranges, and fault lines. The best time to view the Moon is during its crescent or half phase. Sunlight strikes the Moon at an angle during these periods and adds a depth to the view (see Fig 46). No shadows are seen during a full Moon, making the overly bright surface to appear flat and rather uninteresting. Consider the use of a neutral density Moon filter when observing the Moon. See **OPTIONAL ACCESSORIES**. Not only does it cut down the Moon's bright glare, but it also enhances contrast, providing a more dramatic image.

Tracking Objects

As the Earth rotates beneath the night sky, the stars appear to move from East to West. The speed at which the stars move is called the sidereal rate. You can track objects at this rate by using the RA and DEC slow motion control cables(Fig. 1, #19 and #20) on each axis. To properly track night sky objects, it is best to perform a procedure called a polar alignment.

In the northern hemisphere the polar alignment requires pointing the mounts RA axis at the north star Polaris as accurately as possible. In the southern hemisphere the polar alignment requires pointing at the southern celestial pole. For using the telescope visually, high precision is not needed for the polar alignment. Only when using the telescope for astrophotography will higher precision for the polar alignment be necessary.

To point at Polaris, start by aiming the north leg of the tripod north. Adjust the latitude(Fig. 1, #6) and azimuth(Fig. 1, #5) mount adjustments so that you can see Polaris through the polar axis view port(Fig. 1, #22).

An optional polar axis scope is available if a higher precision alignment is desired. See **OPTIONAL ACCESSORIES**. Polaris will be positioned at an altitude equal to your observing sites latitude. If you know your local latitude simply adjust the front and back latitude adjustment bolts until the indicator points to your local latitude on the scale(Fig. 1, #8). To find your local latitude you can consult a road map, look it up on the Internet, or see **Appendix C: LATITUDE CHART**.

Locating the Celestial Pole

In the northern Hemisphere, find the North Star Polaris by facing North. To get basic bearings at an observing location, take note of where the Sun rises (East) and sets (West) each day. After the site is dark, face North by pointing your left shoulder toward where the Sun set. To precisely point at the pole, find the North Star (Polaris) by using the Big Dipper as a guide (See figure below).

In the southern Hemisphere, you align the mount to the southern celestial pole. To do this it is necessary to reference star patterns since the southern celestial pole has no nearby bright stars. The closest bright star to the south celestial pole is Sigma Octanis, which is about one degree away. Using Sigma Octanis and other bright stars will help you locate the pole.

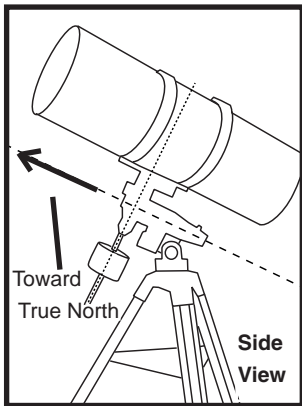

Figure 30: RA Polar Axis toward True North (Polaris)

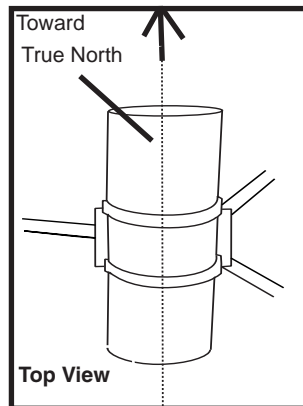

Figure 31: RA Polar Axis toward True North (Polaris)

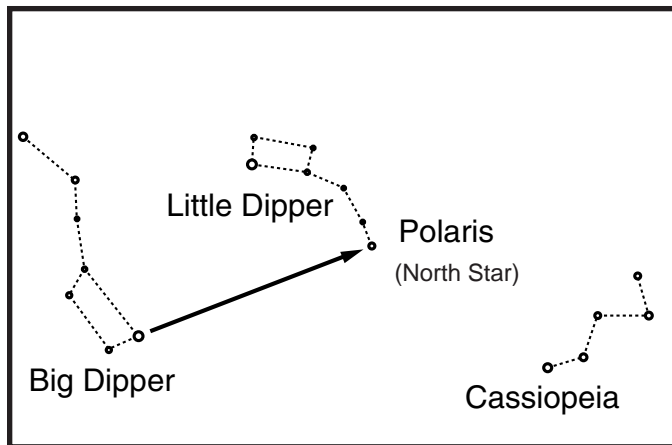

Figure 32 : Finding Polaris (North Star) For Northern Hemisphere observers



Figure 29: Latitude Scale with pointer

Maintenance

General Maintenance

LX70-Series telescopes are precision optical instruments designed to yield a lifetime of rewarding views. Given the care and respect due any precision instrument, your LX70 will rarely, if ever, require factory servicing. Maintenance guidelines include:

a. Avoid cleaning the telescope's optics: A little dust on the mirrors or the front surface of the telescope's lens causes virtually no degradation of image quality and should not be considered reason to clean the lens.

b. When absolutely necessary, dust on the mirrors or front lens should be removed with gentle strokes of a camel hair brush or blown off with an ear syringe (available at any pharmacy). **DO NOT** use a commercial photographic lens cleaner.

c. Organic materials (e.g., fingerprints) on the front lens may be removed with a solution of 3 parts distilled water to 1 part isopropyl alcohol. You may also add 1 drop of biodegradable dishwashing soap per pint of solution. Use soft, white facial tissues and make short, gentle strokes. Change tissues often. Caution: Do not use scented or lotion tissues or damage could result to the optics.

d. If the LX70 is used outdoors on a humid night, water condensation on the telescope surfaces will probably result. While such condensation does not normally cause any damage to the telescope, it is recommended that the entire telescope be wiped down with a dry cloth before the telescope is packed away. Do not, however, wipe any of the optical surfaces. Rather, simply allow the telescope to sit for some time in the warm indoor air, so that the wet optical surfaces can dry unattended.

Inspecting the Optics

A Note about the Flashlight Test: If a flashlight or other high-intensity light source is pointed down the main telescope tube, the view (depending upon the observer's line of sight and the angle of the light) may reveal what appears to be scratches, dark or bright spots, or just generally uneven coatings, giving the appearance of poor quality optics. These items are only seen when a high intensity light is transmitted through lenses or reflected off the mirrors, and can be seen on any high quality optical system, including giant research telescopes. The optical quality of a telescope cannot be judged by the "flashlight test;" the true test of optical quality can only be conducted through careful star testing.

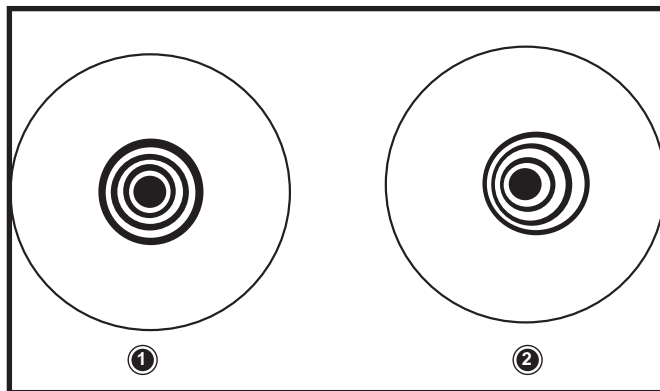

Figure 33: Correct (1) and incorrect (2) collimation as viewed during a star test

Alignment (Collimation) of the Newtonian Reflector OTA

The optical systems of Newtonian Reflector telescopes include the following parts: primary mirror (Fig. 34, #1); secondary mirror (Fig. 34, #2); secondary mirror-holder (Fig. 34, #3); secondary mirror-vanes (Fig. 34, #4) and (Fig. 35, #1); primary mirror-tilt screws (Fig. 34, #5). The telescope's image is brought to a focus at (Fig. 34, #6).

1. Confirm alignment - To confirm optical alignment look down the focuser drawtube (Fig. 37, #1) with the eyepiece removed. The edge of the focuser drawtube frames reflections of the primary mirror (Fig. 37, #2), the secondary mirror (Fig. 37, #3), the four ("spider") vanes (Fig. 37, #4) holding the secondary mirror, and the observer's eye (Fig. 37, #5). With the optics properly aligned, all of these reflections appear concentric (centered), as shown in Fig. 37. Any deviation from concentricity of any of these telescope parts with the eye requires adjustments to the secondary mirror-holder (Fig. 35) and/or the primary mirror cell (Fig. 36), as described below.

2. Secondary mirror-vane adjustments: If the secondary mirror (1, Fig. 38) is left or right of center within the drawtube (Fig. 38, #2), slightly loosen the 3 collimation screws on the top of the secondary mirror holder (Fig. 35, #2). Next, tighten or loosen as necessary, the central Phillips screw to center the secondary mirror position in the focuser draw tube. When correctly positioned, lightly tighten the 3 collimation screws (Fig. 35, #2) until they touch the top of the secondary mirror. The secondary mirror should now be centered in the focuser drawtube left or right. If the secondary mirror (Fig. 38, #1) is above- or below-center within the drawtube, thread inward one of the adjustment/lock knobs (Fig. 35, #1) while unthreading another of these knobs. Only make adjustments to two knobs at a time until the secondary mirror appears as in Fig. 39.

3. Secondary mirror-holder adjustments: If the secondary mirror (Fig. 39, #1) is centered in the focuser drawtube (Fig. 39, #2), but the primary mirror is only partially visible in the reflection (Fig. 39, #3), the three secondary mirror collimation screws (Fig. 35, #2) should be slight-

ly unthreaded to the point where the secondary mirror-holder (Fig. 35, #3) can rotate about its axis parallel to the main tube. Grasp the secondary mirror-holder (avoid touching the mirror surface!) with your hand and rotate it until, looking through the drawtube, you can see the primary mirror centered as well as possible in the reflection of the secondary mirror. With the rotation of the secondary mirror-holder at this best-possible position, thread in the three secondary collimation screws (Fig. 35, #2) to lock the rotational position. Then, if necessary, make adjustments to these three collimation screws to refine the tilt-angle of the secondary mirror, until the entire primary mirror can be seen centered within the secondary mirror's reflection. With the secondary mirror thus aligned the image through the drawtube appears as in Fig. 40.

4. Primary mirror adjustments: If the secondary mirror (Fig. 40, #1) and the reflection of the primary mirror (Fig. 40, #2) appear centered within the drawtube (Fig. 40, #3), but the reflection of your eye and the reflection of the secondary mirror (Fig. 40, #4) appear off-center, then the primary mirror tilt requires adjusting, using the Phillips head screws of the primary mirror cell (Fig. 36, #3). These primary mirror-tilt screws are located behind the primary mirror, at the lower end of the main tube. See Fig. 36. Before adjusting the primary mirror-tilt screws, first unscrew by several turns the three long primary mirror lock screws (Fig. 36, #2) which are also located on the rear surface of the primary mirror cell and which alternate around the cell's circumference with the three long and thin thumbscrews. These lock screws do not have springs beneath them. Then by trial and error turn the primary mirror tilt thumbscrews (Fig. 36, #3) until you develop a feel for which way to turn each screw to center the reflection of your eye in the drawtube. (An assistant is helpful in this operation.) With your eye centered as shown in Fig. 37, turn the three long and thin mirror lock screws (Fig. 36, #2) to re-lock the tilt-angle of the primary mirror.

5. The telescope's optical system is now aligned, or collimated. This collimation should be re-checked from time to time, with small adjustments (per steps 1, 2, and/or 3, above) effected as required to keep the optics well-aligned.

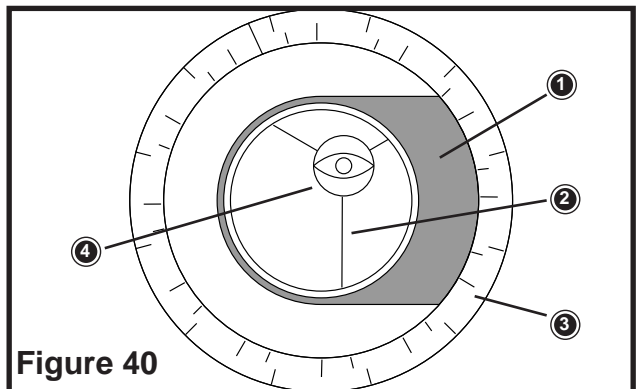
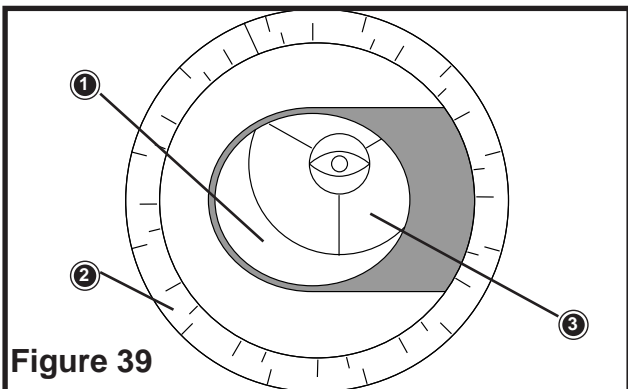
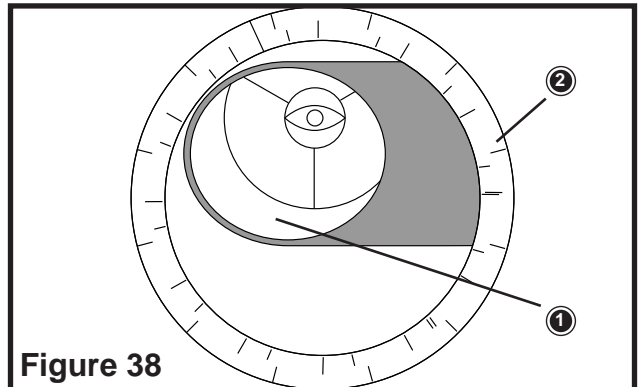
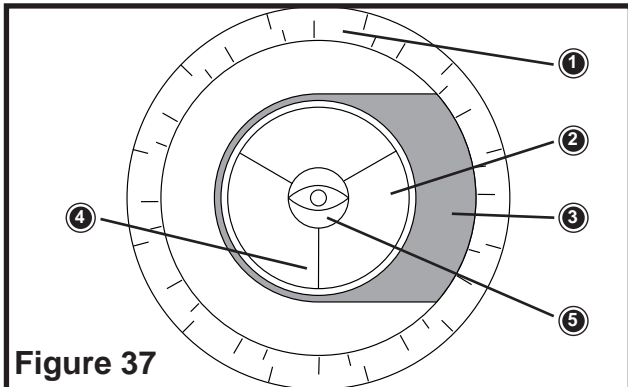
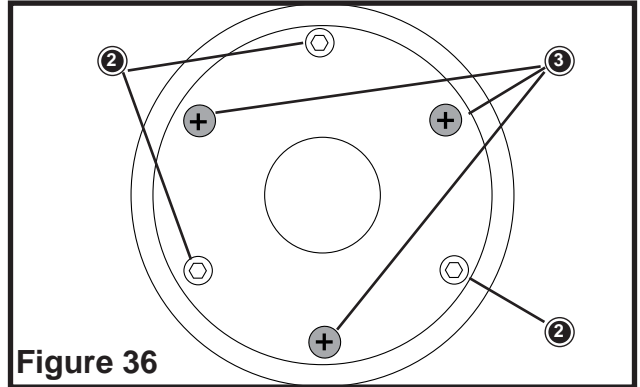
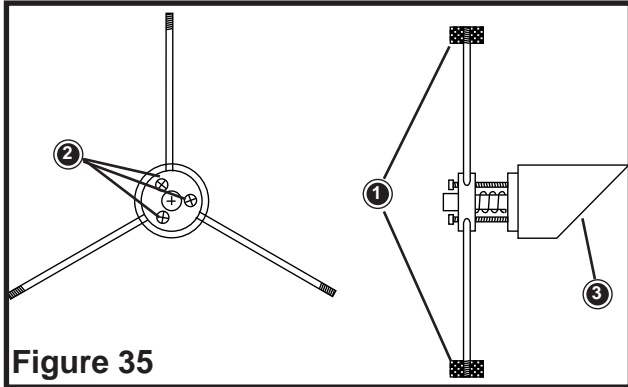
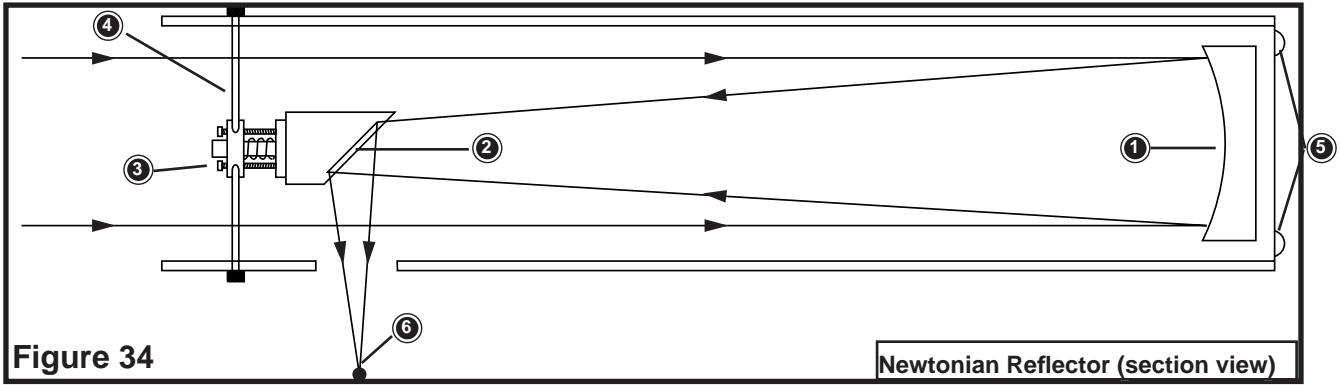

OPTIONAL ACCESSORIES

A wide assortment of professional Meade accessories is available for the LX70 Series telescope models. The premium quality of these accessories is well-suited to the quality of the instrument itself. Consult the Meade Website (www.meade.com) for complete details on these and other accessories.

#670010 LX70 Polar Scope: The Meade LX70 Polar scope is designed to assist the user in performing a polar alignment on the night sky. The polar scope includes a reticule pattern which is used in the alignment process, making the LX70 polar scope even more user friendly. As a result, the LX70 mount can be aligned with a higher precision and allows the user to more quickly enjoy the night sky. See the Meade website for more details.

#670011 LX70 Motor Drive Kit: The LX70 motor drive kit attaches to both telescope axes. The motor drive kit allows tracking of celestial objects at the speed of the earth's rotation. The included hand controller is used to adjust the mount when using the mount for astrophotography. Use of the LX70 motor drive kit requires the LX70 mount to be properly polar aligned on the night sky. See the Meade website for more details.

Laser Collimator: Meade's Laser collimator helps make collimation of Newtonian telescopes quick and easy. Collimation is a method to align your telescope's optics. Your telescope is aligned at the factory, but shipping and handling can sometimes mis-align collimation. Misaligned collimation can mean dimmer and blurrier images in your telescope eyepiece. Make collimation quick and easy with a Meade laser collimator.

Series 4000 8 - 24mm Zoom Eyepiece: The internal zoom optics of this eyepiece move on smooth, precisely machined surfaces which maintain optical collimation at all zoom settings. A scale graduated in 1mm units indicates the zoom focal length in operation. An excellent addition to any eyepiece set.

#140 2x Barlow Lens: A 3-element design, doubles each eyepiece power while maintaining uncompromised image resolution, color correction, and contrast. Insert the #140 into the telescope's eyepiece holder first, followed by the diagonal (as applicable) and eyepiece. The #126 2x Barlow Lens, a compact 2-element alternative to the #140, may also be employed with any LX70 Series telescope.

#905 Variable Polarizer (1.25"): The #905 system includes 2 Polarizer filters mounted in a specially-machined cell, for glare-reduction in observing the Moon. Rotate the thumbscrew at the side of the unit to achieve light transmission between 5% and 25% of its original value. The #905 inserts into the diagonal of the telescope, followed by an eyepiece.

Series 4000 Photo-Visual Color Filters: Color filters significantly enhance visual and photographic image contrast of the Moon and planets. Each filter threads into the barrel of any Meade 1.25" eyepiece, and into the barrels of virtually all other eyepiece brands as well. Meade filters are available in 12 colors for lunar and planetary applications, and in Neutral Density as a lunar glare-reduction filter.

Series 4000 Nebular Filters: A modern boon to the city-dwelling deep-space observer, the interference nebular filter effectively cancels out the effects of most urban light pollution, while leaving the light of deep-space nebular emissions virtually un-attenuated. Meade Series 4000 Nebular Filters utilize the very latest in coating technology, and are available with threaded cells for eyepieces or for attachment to the rear cells of Meade ACF telescopes.

#91101 Meade LED Flashlight: The LED flashlight features a very bright beam from 16 LED's and is push button selectable from white for normal illumination to red to preserve night vision. Heavy duty metal construction, with threaded battery compartment. (3 "AAA" batteries required.)

Meade Series 4000 Eyepiece and Filter Set: Complete set of the most popular accessories. Includes six popular Meade Series 4000 Super Plossl Eyepieces in focal lengths of 6.4mm, 9.7mm, 12.4mm, 15mm, 32mm and 40mm. All eyepieces feature a standard 1.25" barrel size, with a 52° apparent field of view and are of a 4-element design with premium optical glass. This kit also contains a Meade Series 4000 Color Filter Set #1 including high quality "dyed in glass" #12 Yellow, #23 Light Red, #58 Green and # 80A Blue filters which are very useful for bringing out various details on the planets. There is also a Series 4000 ND96 Moon Filter to reduce glare and increase clarity when observing the Moon.

To find out more about these and other accessories available for your telescope, check out the Meade website or contact your local Meade dealer.

APPENDIX A: Celestial Coordinates

A celestial coordinate system was created that maps an imaginary sphere surrounding the Earth upon which all stars appear to be placed. This mapping system is similar to the system of latitude and longitude on Earth surface maps.

In mapping the surface of the Earth, lines of longitude are drawn between the North and South Poles and lines of latitude are drawn in an East-West direction, parallel to the Earth's equator. Similarly, imaginary lines have been drawn to form a latitude and longitude grid for the celestial sphere. These lines are known as Right Ascension and Declination.

The celestial map also contains two poles and an equator just like a map of the Earth. The poles of this coordinate system are defined as those two points where the Earth's north and south poles (i.e., the Earth's axis), if extended to infinity, would cross the celestial sphere. Thus, the North Celestial Pole (1, Fig. 41) is that point in the sky where an extension of the North Pole intersects the celestial sphere. The North Star, Polaris is located very near the North Celestial Pole. The celestial equator (2, Fig. 41) is a projection of the Earth's equator onto the celestial sphere. Just as an object's position on the Earth's surface can be located by its latitude and longitude, celestial objects may also be located using Right Ascension and Declination. For example, you could locate Los Angeles, California, by its latitude ($+34^\circ$) and longitude (118°). Similarly, you could locate the Ring Nebula (M57) by its Right Ascension (18hr) and its Declination ($+33^\circ$).

Right Ascension (R.A.): This celestial version of longitude is measured in units of hours (hr), minutes (min), and seconds (sec) on a 24-hour "clock" (similar to how Earth's time zones are determined by longitude lines). The "zero" line was arbitrarily chosen to pass through the constellation Pegasus — a sort of cosmic Greenwich meridian. R.A. coordinates range from 0hr 0min 0sec to 23hr 59min 59sec. There are 24 primary lines of R.A., located at 15-degree intervals along the celestial equator. Objects located further and further East of the zero R.A. grid line (0hr 0min 0sec) carry higher R.A. coordinates.

Declination (Dec.): This celestial version of latitude is measured in degrees, arc-minutes, and arc-seconds (e.g., $15^\circ 27' 33''$). Dec. locations north of the celestial equator are indicated with a plus (+) sign (e.g., the Dec. of the North celestial pole is $+90^\circ$). Dec. locations south of the celestial equator are indicated with a minus (-) sign (e.g., the Dec. of the South celestial pole is -90°). Any point on the celestial equator (such as the constellations of Orion, Virgo, and Aquarius) is said to have a Declination of zero, shown as $0^\circ 0' 0''$.

APPENDIX B: Setting Circles

Setting circles permit the location of faint celestial objects not easily found by direct visual observation. With the telescope pointed at the North Celestial Pole, the Dec. circle (see Fig. 43) should read 90° (understood to mean $+90^\circ$). Each division of the Dec. circle represents a 1° increment. The R.A. circle (see Fig. 42) runs from 0hr to (but not including) 24hr, and reads in increments of 10 minutes. Using setting circles requires a developed technique. When using the circles for the first time, try hopping from one bright star (the calibration star) to another bright star of known coordinates.

Practice moving the telescope from one easy-to-find object to another. In this way, the precision required for accurate object location becomes evident.

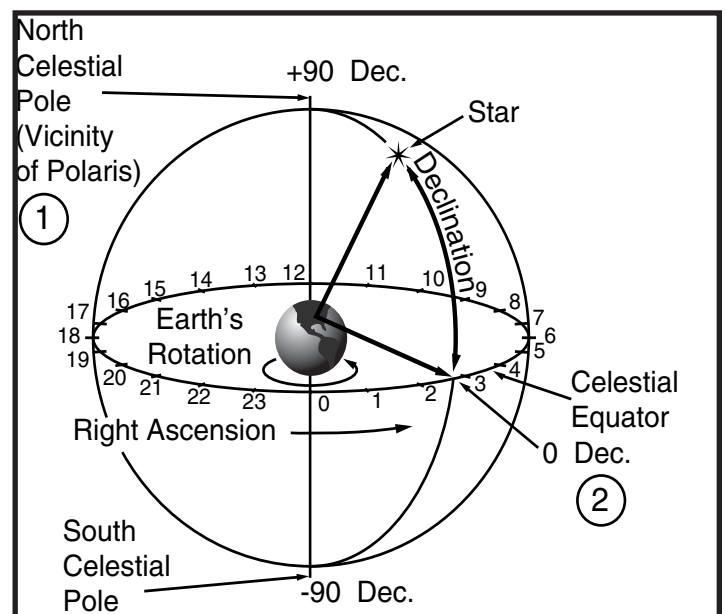

Figure 41: Celestial Sphere

APPENDIX B:

Setting Circles

To use the setting circles to locate an object not easily found by direct visual observation: Insert a low-power eyepiece, such as a 26mm, into the focuser assembly. Pick out a bright star with which you are familiar (or is easily located) that is in the area of the sky in which your target object is located. Look up the R.A. coordinate of the bright star, and also of the object you wish to locate, in a star atlas or on the internet. Point the telescope at the bright star. Then loosen the R.A. setting circle lock knob (see Fig. 42) and turn the R.A. setting circle to read the correct R.A. coordinate of the bright star; lock the R.A. setting circle lock knob to secure the setting circle in place (If you are in the northern hemisphere, use the top numbers on the RA setting circle. If you are in the southern hemisphere use the bottom numbers.) Next, adjust the DEC setting circle by moving the setting circle ring until

the objects DEC coordinate is aligned with the 0 registration mark. If the procedure has been followed carefully, the bright star should now be in the center of the telescope eyepiece and setting circles showing the bright star coordinates.

To locate another object, unlock the RA and DEC locks and move the telescope so the RA and DEC setting circle coordinates match the target object. Then lock each axis and use the slow motion controls to track the object.

If when using the setting circles to locate objects, you do not immediately see the object you are seeking, try searching the adjacent sky area. Start with the 26mm eyepiece when locating object since it has a wider field of view than the 9mm. Because of its much wider field, the viewfinder may be of significant assistance in locating and centering objects, after the setting circles have been used to locate the approximate position of the object.

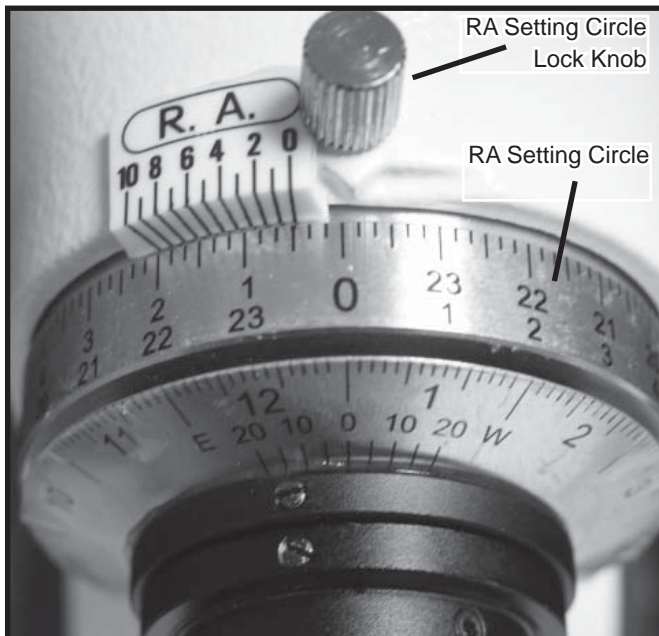

Figure 42: RA setting circle and lock knob

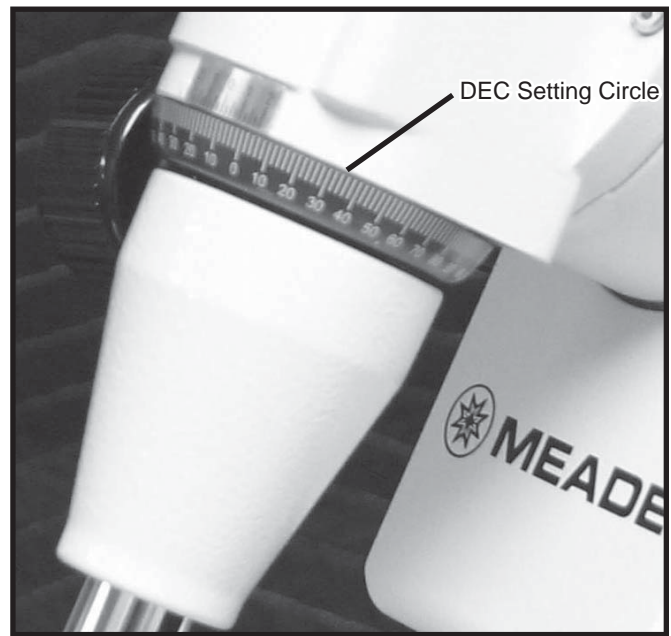

Figure 43: DEC setting circle

APPENDIX C:

Latitude Chart

Latitude Chart for Major Cities of the World

To aid in the polar alignment procedure, latitudes of major cities around the world are listed below. To determine the latitude of an observing site not listed on the chart, locate the city closest to your site or locate your site on the internet. Then follow the procedure below:

Northern hemisphere observers (N): If the site is over 70 miles (110 km) north of the listed city, add one degree for every 70 miles. If the site is over 70 miles South of the listed city, subtract one degree per 70 miles.

Southern Hemisphere observers (S): If the site is over 70 miles (110 km) north of the listed city, subtract one degree for every 70 miles. If the site is over 70 miles South of the listed city, add one degree per 70 miles.

NORTH AMERICA			EUROPE (continued)		
City	State/Prov./Country	Latitude	City	Country	Latitude
Albuquerque	New Mexico	35° N	Oslo	Norway	60° N
Anchorage	Alaska	61° N	Paris	France	49° N
Atlanta	Georgia	34° N	Rome	Italy	42° N
Boston	Massachusetts	42° N	Stockholm	Sweden	59° N
Calgary	Alberta	51° N	Vienna	Austria	48° N
Chicago	Illinois	42° N	Warsaw	Poland	52° N
Cleveland	Ohio	41° N	SOUTH AMERICA		
Dallas	Texas	33° N	City	Country	Latitude
Denver	Colorado	40° N	Bogotá	Colombia	4° N
Detroit	Michigan	42° N	São Paulo	Brazil	23° S
Honolulu	Hawaii	21° N	Buenos Aires	Argentina	35° S
Jackson	Mississippi	32° N	Montevideo	Uruguay	35° S
Kansas City	Missouri	39° N	Santiago	Chile	34° S
Kenosha	Wisconsin	45° N	Caracas	Venezuela	10° N
Las Vegas	Nevada	36° N	ASIA		
Little Rock	Arkansas	35° N	City	Country	Latitude
Los Angeles	California	34° N	Beijing	China	40° N
Mexico City	Mexico	19° N	Hong Kong	China	23° N
Miami	Florida	26° N	Seoul	South Korea	37° N
Minneapolis	Minnesota	45° N	Taipei	Taiwan	25° N
Nashville	Tennessee	36° N	Tokyo	Japan	36° N
New Orleans	Louisiana	30° N	Sapporo	Japan	43° N
New York	New York	41° N	Bombay	India	19° N
Oklahoma City	Oklahoma	35° N	Calcutta	India	22° N
Ottawa	Ontario	45° N	Hanoi	Vietnam	21° N
Philadelphia	Pennsylvania	40° N	Jedda	Saudi Arabia	21° N
Phoenix	Arizona	33° N	AFRICA		
Portland	Oregon	46° N	City	Country	Latitude
Salt Lake City	Utah	41° N	Cairo	Egypt	30° N
San Antonio	Texas	29° N	Cape Town	South Africa	34° S
San Diego	California	33° N	Rabat	Morocco	34° N
San Francisco	California	38° N	Tunis	Tunisia	37° N
Seattle	Washington	47° N	Windhoek	Namibia	23° S
Washington	District of Columbia	39° N	AUSTRALIA AND OCEANIA		
EUROPE			City	State/Country	Latitude
City	Country	Latitude	Adelaide	South Australia	35° S
Amsterdam	Netherlands	52° N	Brisbane	Queensland	27° S
Athens	Greece	38° N	Canberra	New South Wales	35° S
Bern	Switzerland	47° N	Alice Springs	Northern Territory	24° S
Copenhagen	Denmark	56° N	Hobart	Tasmania	43° S
Dublin	Ireland	53° N	Perth	Western Australia	32° S
Frankfurt	Germany	50° N	Sydney	New South Wales	34° S
Glasgow	Scotland	56° N	Melbourne	Victoria	38° S
Helsinki	Finland	60° N	Auckland	New Zealand	37° S
Lisbon	Portugal	39° N			
London	England	51° N			
Madrid	Spain	40° N			

Figure 44: Latitude for major cities

APPENDIX D:

Basic Astronomy

In the early 17th century Italian Scientist Galileo, using a telescope smaller than your LX70, turned it skyward instead of looking at the distant trees and mountains. What he saw, and what he realized about what he saw, has forever changed the way mankind thinks about the universe. Imagine what it must have been like being the first human to see moons revolve around the planet Jupiter or to see the changing phases of Venus! Because of his observations, Galileo correctly realized Earth's movement and position around the Sun, and in doing so, gave birth to modern astronomy. Yet Galileo's telescope was so crude, he could not clearly make out the rings of Saturn. Galileo's discoveries laid the foundation for understanding the motion and nature of the planets, stars, and galaxies. Building on his foundation, Henrietta Leavitt determined how to measure the distance to stars, Edwin Hubble gave us a glimpse into the possible origin of the universe, Albert Einstein unraveled the crucial relationship of time and light, and 21st-century astronomers are currently discovering planets around stars outside our solar system. Almost daily, using sophisticated successors to Galileo's telescope, such as the Hubble Space Telescope and the Chandra X-Ray Telescope, more and more mysteries of the universe are being probed and understood.

We are living in the golden age of astronomy. Unlike other sciences, astronomy welcomes contributions from amateurs. Much of the knowledge we have on subjects such as comets, meteor showers, double and variable stars, the Moon, and our solar system comes from observations made by amateur astronomers. So as you look through your Meade telescope, keep in mind Galileo. To him, a telescope was not merely a machine made of glass and metal, but something far more—a window of incredible discovery. Each glimpse offers a potential secret waiting to be revealed.

Objects in Space Listed below are some of the many astronomical objects that can be seen with your telescope:

The Moon is, on average, a distance of 239,000 miles (380,000km) from Earth and is best ob-

served during its crescent or half phase when Sunlight strikes the Moon's surface at an angle. It casts shadows and adds a sense of depth to the view. No shadows are seen during a full Moon, causing the overly bright Moon to appear flat and rather uninteresting through the telescope. Be sure to use a neutral Moon filter when observing the Moon. Not only does it protect your eyes from the bright glare of the Moon, but it also helps enhance contrast, providing a more dramatic image. Using your telescope, brilliant detail can be observed on the Moon, including hundreds of lunar craters and Maria, described below.

Craters are round meteor impact sites covering most of the Moon's surface. With no atmosphere on the Moon, no weather conditions exist, so the only erosive force is meteor strikes. Under these conditions, lunar craters can last for millions of years.

Maria (plural for mare) are smooth, dark areas scattered across the lunar surface. These dark areas are large ancient impact basins that were filled with lava from the interior of the Moon by the depth and force of a meteor or comet impact. Twelve Apollo astronauts left their boot prints on the Moon in the late 1960's and early 1970's. However, no telescope on Earth is able to see these footprints or any other artifacts. In fact, the smallest lunar features that may be seen with the largest telescope on Earth are about one-half mile across.

Planets change positions in the sky as they orbit around the Sun. To locate the planets on a given day or month, consult a monthly astronomy magazine, such as Sky and Telescope or Astronomy. Listed below are the best planets for viewing through the LX70 telescope.

Venus is about nine-tenths the diameter of Earth. As Venus orbits the Sun, observers can see it go through phases (crescent, half, and full) much like those of the Moon. The disk of Venus appears white as Sunlight is reflected off the thick cloud cover that completely obscures any surface detail.

Mars is about half the diameter of Earth, and appears through the telescope as a tiny reddish-orange disk. It may be possible to see a hint of white at one of the planet's Polar ice caps. Approximately every two years, when Mars is closest to Earth in its orbit, additional detail and

coloring on the planet's surface may be visible. Jupiter is the largest planet in our solar system and is eleven times the diameter of Earth. The planet appears as a disk with dark lines stretching across the surface. These lines are cloud bands in the atmosphere. Four of Jupiter's moons (Io, Europa, Ganymede, and Callisto) can be seen as "star-like" points of light when using even the lowest magnification. These moons orbit Jupiter so that the number of moons visible on any given night changes as they circle around the giant planet.

Saturn is nine times the diameter of Earth and appears as a small, round disk with rings extending out from either side. In 1610, Galileo, the first person to observe Saturn through a telescope, did not understand that what he was seeing were rings. Instead, he believed that Saturn had "ears." Saturn's rings are composed of billions of ice particles ranging in size from a speck of dust to the size of a house. The major division in Saturn's rings, called the Cassini Division, is occasionally visible through medium sized telescopes. Titan, the largest of Saturn's moons can also be seen as a bright, star-like object near the planet.

Deep-Sky Objects: Star charts can be used to locate constellations, individual stars and deep-sky objects. Examples of various deep-sky objects are given below:

Stars are large gaseous objects that are self-illuminated by nuclear fusion in their core. Because of their vast distances from our solar system, all stars appear as pinpoints of light, irrespective of the size of the telescope used.

Nebulae are vast interstellar clouds of gas and dust where stars are formed. Most impressive of these is the Great Nebula in Orion (M42), a diffuse nebula that appears as a faint wispy gray cloud. M42 is 1600 light years from Earth.

Open Clusters are loose groupings of young stars, all recently formed from the same diffuse nebula. The Pleiades is an open cluster 410 light years away. Through the LX70 telescope numerous stars are visible.

Constellations are large, imaginary patterns of stars believed by ancient civilizations to be the celestial equivalent of objects, animals, people, or gods. These patterns are too large to be seen through a telescope. To learn the constellations,

start with an easy grouping of stars, such as the Big Dipper in Ursa Major. Then, use a star chart to explore across the sky.

Galaxies are large assemblies of stars, nebulae, and star clusters that are bound by gravity. The most common shape is spiral (such as our own Milky Way), but galaxies can also be elliptical, or even irregular blobs. The Andromeda Galaxy (M31) is the closest spiral-type galaxy to our own. This galaxy appears fuzzy and cigar-shaped. It is 2.2 million light years away in the constellation Andromeda, located between the large "W" of Cassiopeia and the great square of Pegasus.



Figure 45: Saturn



Figure 46: Craters on the Moon



Figure 47: Jupiter

Meade Customer Service

If you have a question concerning your LX70-Series telescope, contact the Meade Instruments Customer Service Department at:

Telephone: (800) 626-3233.

Customer Service hours are 7:00 AM to 5:00 PM, Pacific Time, Monday through Friday. In the unlikely event that your LX70-Series telescope requires factory servicing or repairs, write or call the Meade Customer Service Department first, before returning the telescope to the factory, giving full particulars as to the nature of the problem, as well as your name, address, and daytime telephone number. The great majority of servicing issues can be resolved by telephone, avoiding return of the telescope to the factory. If factory service is required, you will be assigned a Return Goods Authorization (RGA) number prior to return.

Meade Limited Warranty

Every Meade telescope, spotting scope, and telescope accessory is warranted by Meade Instruments Corp. ("Meade") to be free of defects in materials and workmanship for a period of ONE YEAR from the date of original purchase in the U.S.A. and Canada. Meade will repair or replace a product, or part thereof, found by Meade to be defective, provided the defective part is returned to Meade, freight-prepaid, with proof of purchase. This warranty applies to the original purchaser only and is non-transferable. Meade products purchased outside North America are not included in this warranty, but are covered under separate warranties issued by Meade international distributors.

RGA Number Required: Prior to the return of any product or part, a Return Goods Authorization (RGA) number must be obtained from Meade by writing, or calling (949) 451-1450. Each returned part or product must include a written statement detailing the nature of the claimed defect, as well as the owner's name, address, and phone number.

This warranty is not valid in cases where the product has been abused or mishandled, where unauthorized repairs have been attempted or performed, or where depreciation of the product is due to normal wear-and-tear. Meade specifically disclaims special, indirect, or consequential damages or lost profit which may result from a breach of this warranty. Any implied warranties which cannot be disclaimed are hereby limited to a term of one year from the date of original retail purchase. This warranty gives you specific rights. You may have other rights which vary from state to state. Meade reserves the right to change product specifications or to discontinue products without notice.

OBSERVATION LOG

OBSERVATION LOG

OBSERVATION LOG

© 2014 Meade Instruments Corp. reserves the right to change product specifications or to discontinue products without notice.

12/2014 LX70 SERIES

14-9287-00 Rev 0