

Orion® Ritchey-Chrétien Astrographs

#8268 6" f/9 RC

#8267 8" f/8 RC

#8266 10" f/8 RC



#8266

#8267

#8268



Providing Exceptional Consumer Optical Products Since 1975

OrionTelescopes.com

Customer Support (800) 676-1343 • E-mail: support@telescope.com

Corporate Offices (831) 763-7000 • 89 Hangar Way, Watsonville, CA 95076

Congratulations on your purchase of an Orion Ritchey-Chretien astrograph. These compact but large-aperture telescopes are designed and optimized for high-performance astrophotography with CCD and DSLR cameras. Sporting an optical design comprising hyperbolic primary and secondary mirrors, the RC is highly regarded by advanced astrophotographers and professional observatories worldwide. Even the vaunted Hubble Space Telescope is an RC! Orion RCs deliver exceptional image quality and resolution with zero image shift, minimal coma, a highly baffled steel tube for outstanding contrast, and exclusive mounting options for optional finder scopes and guide scopes. Any one of these superb instruments, when paired with a good mount, will take your imaging pursuits to a whole new and very exciting level.

Parts List

- 1 Optical tube assembly
- 1 2" Extension ring
- 2 1" Extension rings
- 1 Battery holder (10" RC only)
- 1 Starry Night SE digital download coupon

Unpacking Your Telescope

Use care when unpacking the shipping carton. We recommend keeping the boxes and all original packaging materials. In the event that the telescope needs to be shipped to another location, or returned for warranty repair, having the proper packaging will ensure that your telescope will survive the journey intact. Returns for refund or exchange will not be accepted without all of the original packaging. Once all items have been removed from the box take a moment to confirm that all pieces are present and intact. Refer to the Parts List to aid in identifying the included items.

The Focuser

All Orion Ritchey-Chretien telescopes come standard with a machined, all-aluminum, dual-speed focuser. The 6" RC features a 2" Crayford focuser equipped with a removable 1.25" adapter (**Figure 1A**). The 8" RC has a 2" linear-bearing Crayford focuser, which has a stabilizing track on the underside of the drawtube that provides extra rigidity for carrying heavy payloads (**Figure 2**). Drawtube flexure is virtually eliminated by stabilizing the drawtube within the focuser housing. The 10" RC also boasts a linear bearing focuser, but with an oversized housing and a larger 3.3" drawtube that terminates in a 2" accessory collar.

The focuser on all three RCs has a 10:1 fine focus adjustment. Every 10 turns of the small knob equals a single turn of the large knob, to enable the micro-adjustment necessary for the sharpest images possible. Use the coarse focus knob to adjust the telescope until your object is as close to focus as possible, then make fine adjustments with the black outside knob.

Each focuser is also equipped with both a tension adjustment knob for the drawtube and a drawtube locking knob. On the 6" RC both knobs are on the underside of the focuser (**Figure 1B**), whereas on the 8" and 10" models the tension adjustment knob is on the underside of the focuser while the larger locking knob is on top (**Figure 2**). We recommend keeping the tension adjustment knob fairly tight at all times as this will minimize drawtube flexure and slippage.

The focuser can be rotated to a desired angle prior to final focusing for astrophotographic framing by slightly loosening the focuser attachment collar (turning it counterclockwise), then rotating the focuser to the desired position, then retightening the collar.

WARNING: *Never look directly at the Sun with the naked eye or with a telescope – unless you have a proper solar filter installed over the front of the telescope! Otherwise, permanent, irreversible eye damage may result.*

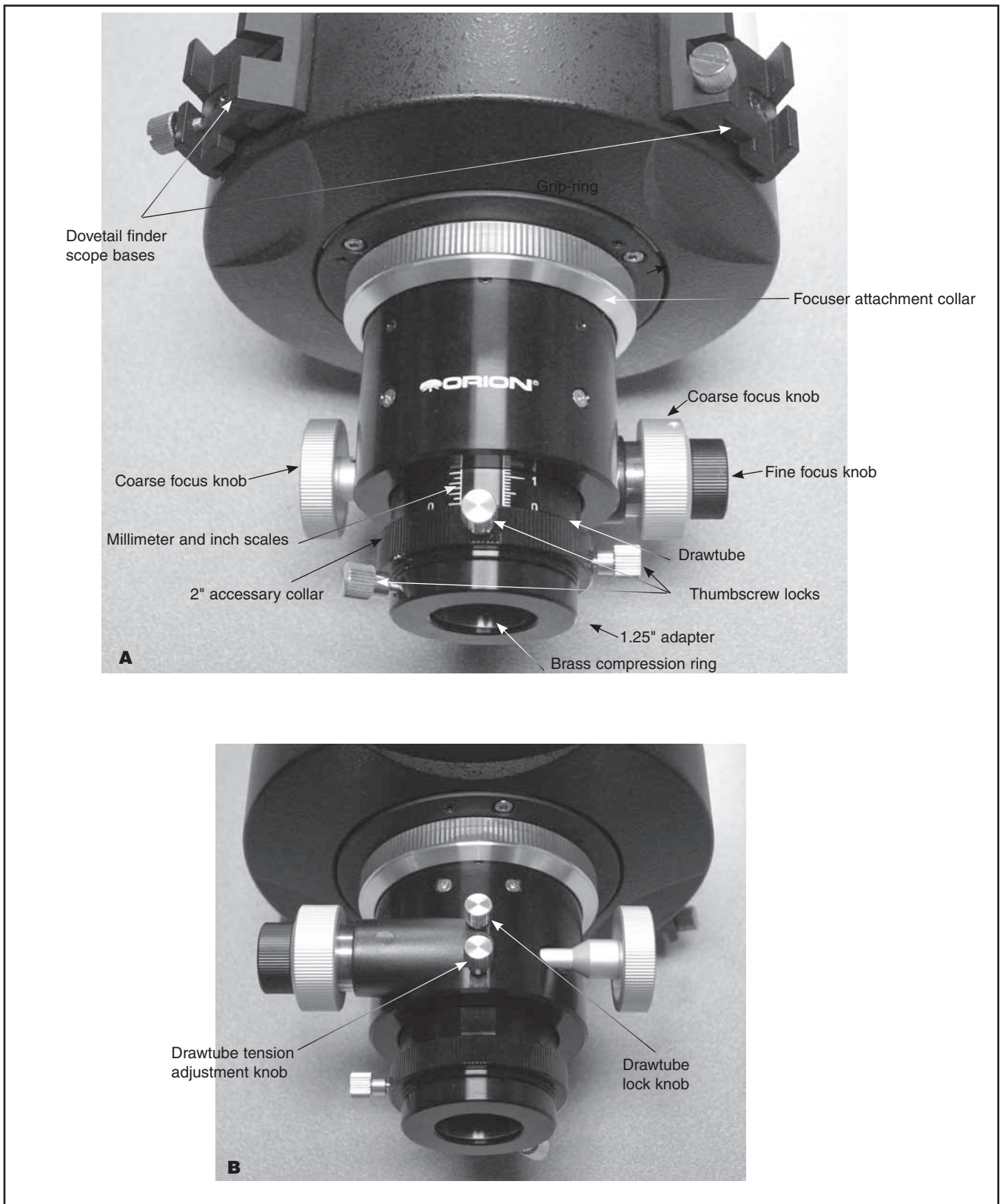

Figure 1. A) The 6" RC's Crayford focuser, top view. B) Both the drawtube tensioning and lock knobs are located on the underside of the focuser.

Extension Rings

Included with your RC telescope are three thread-on extension rings (**Figure 3**). These extension rings are provided to allow multiple visual or photographic accessories to reach focus, depending on their backfocus requirements. They are designed for installation individually or in combination between the optical tube and the focuser to take up unneeded backfocus. *Refer to the Specifications at the end of this manual for the native backfocus distance of each Ritchey-Chretien model.*

If the focuser drawtube is fully extended and you are still unable to achieve focus you will need to install one or more extension rings. To do so you must first remove the focuser from the optical tube by rotating the focuser attachment collar counterclockwise (refer to **Figure 2**). Once you have threaded on the desired number of extension rings onto the male threads on the telescope tube, re-attach the focuser by aligning the silver attachment collar over the exposed extension ring threads and tighten by carefully turning clockwise (**Figure 4**). It may be useful to experiment with different combinations during the day before heading out into the field. Choose a target over ½ mile away to ensure you are simulating infinity focus. The goal is to reach focus with as little extension of the focuser drawtube as possible, to avoid drawtube flexure.

Depending on what equipment you use to observe or image with, you may need to add one or more of the included extension rings. The examples listed and pictured in **Figure 5** are

of common scenarios. So for instance, for DSLR cameras and most visual applications you will need 3" of extension (one 1" ring and one 2" ring) between the OTA and the focuser. Larger 2" eyepieces may require only 2" of extension. Some setups may require combinations different from those shown. The backfocus distance of your camera's sensor as well as the other components in your imaging train, e.g., focal reducer or flattener, filter wheel, or off-axis guider, will influence how much extension you will need to add between the OTA and the focuser in order to reach focus.



Figure 3. Each RC comes with one 2" and two 1" extension rings.

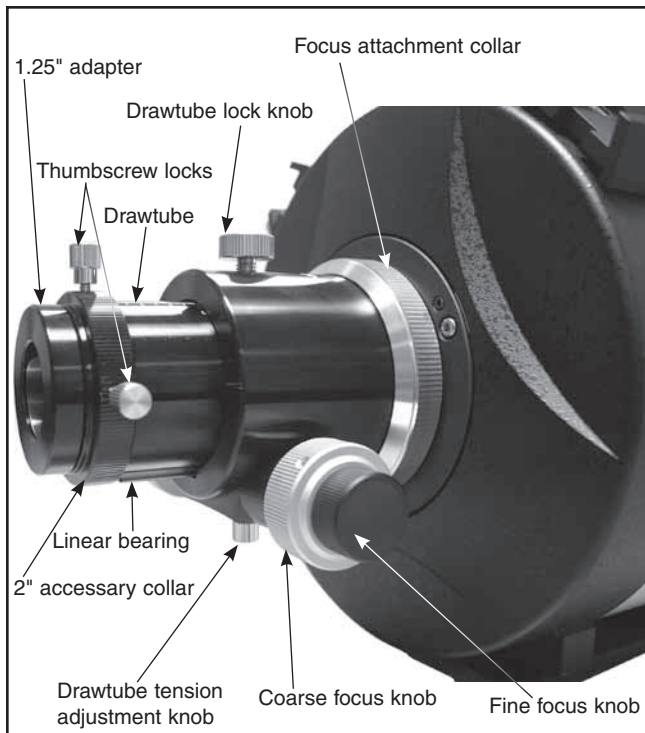

Figure 2. The linear bearing Crayford focuser on the 8" and 10" RCs provide extra drawtube rigidity to support heavy camera loads. (8" RC shown)

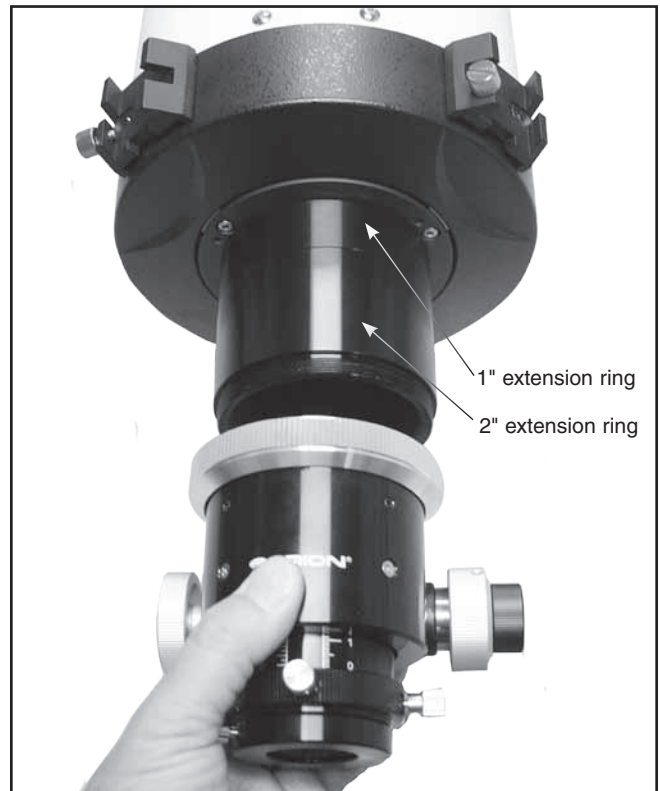

Figure 4. Extension rings are installed between the telescope's rear cell and the focuser, to take up unneeded backfocus.

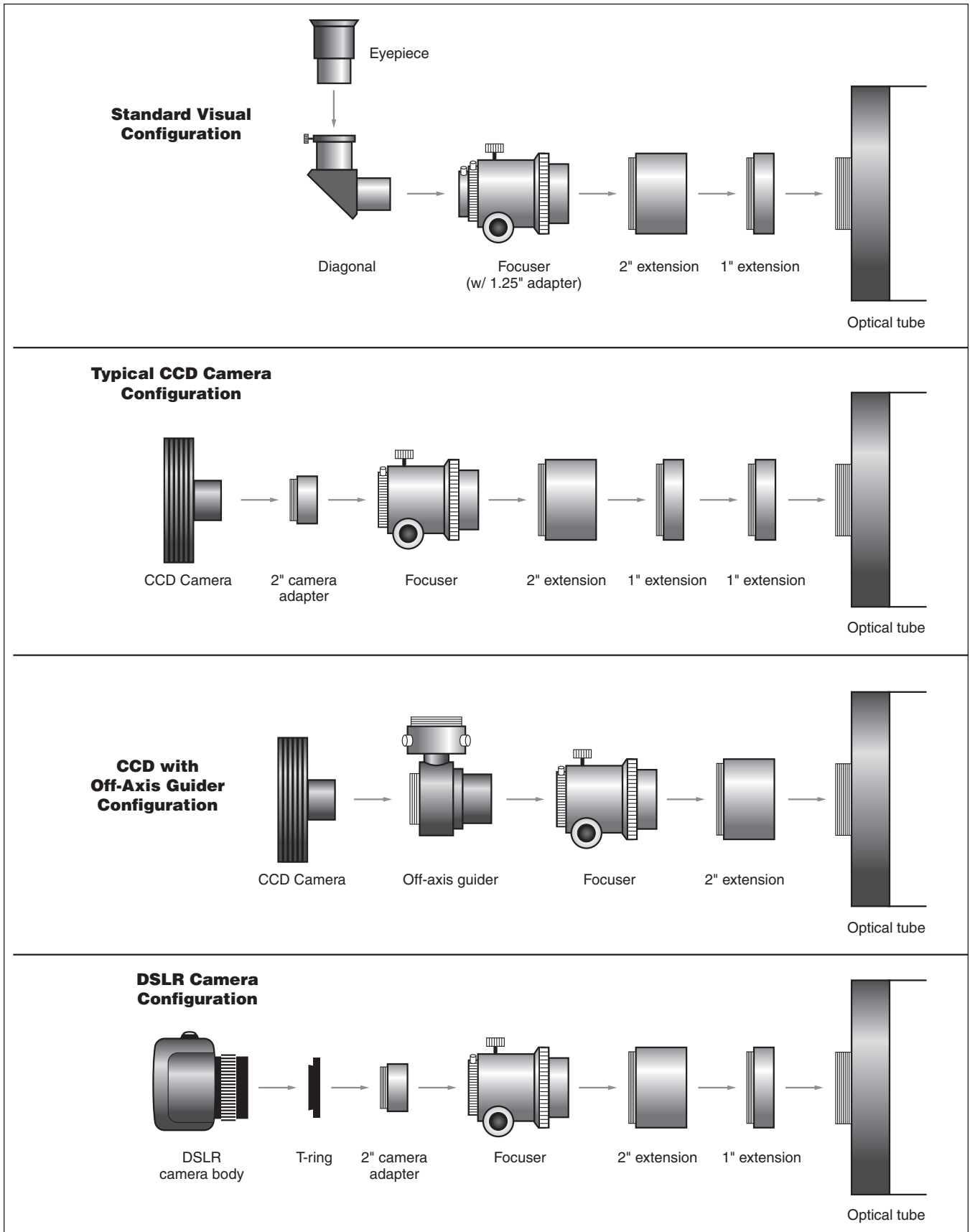

Figure 5. Connection diagrams for typical RC uses.



Figure 6. Two included finder scope dovetail bases allow installation of an optional mini 50mm guidescope and autoguide camera on one side of the focuser and an optional finder scope on the other. (6" RC shown)

Attaching Optional Finder Scopes and Guiding Solutions

Unlike other Ritchey-Chretien telescopes on the market, Orion RCs feature two dovetail finder scope bases on opposite sides of the telescopes' vertical mid-line (refer to **Figure 1A**), to allow maximum versatility of placement for optional finder scopes, reflex sights, or a mini guidescope. Having two dovetail bases gives you the option of placing a finder scope on either the left or right side of the focuser, depending on your preference, or of mounting both a red-dot sight and a traditional achromatic finder scope on the telescope simultaneously. For imaging, you may even wish to install a small

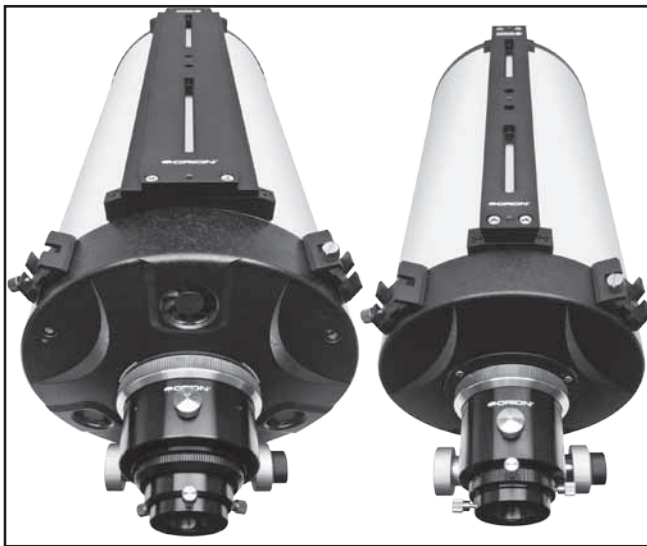

Figure 7. Slotted plates on the top side of the 8" and 10" RCs allow mounting of a guide scope for astrophotography or of another, auxiliary telescope.

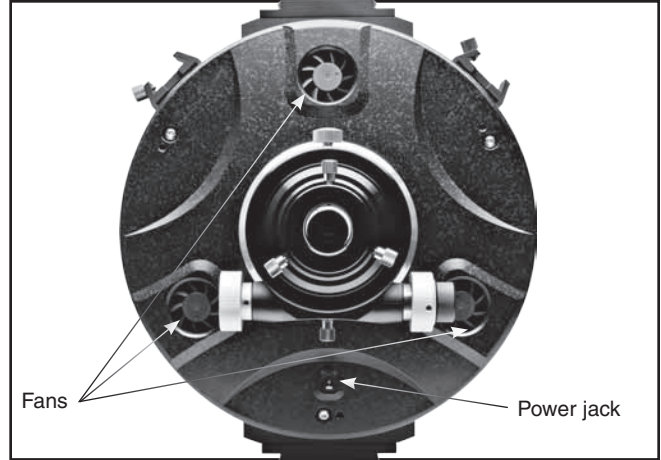

Figure 8. The 10" RC is equipped with three integrated 12V DC cooling fans, which are powered by user-supplied AA batteries

guidescope such as the Orion 50mm Mini GuideScope in one of the dovetail bases along with a reflex sight or another finder scope for visual use in the other, as shown in **Figure 6**. The choice is yours!

The 8" and 10" RCs also feature slotted universal dovetail bars on top of the tube (**Figure 7**), custom designed by Orion, to allow mounting of a guidescope or a DSLR camera for piggyback photography, or even a second, piggybacked telescope for visual use or imaging. The top bar on the 8" RC is a Vixen-style bar while the bar on top of the 10" is a wider, Losmandy-style bar. With two long slots and multiple through-holes, these solid aluminum bars can be used to mount guide scope rings or tube rings spaced apart by the distance you need for your guide scope or second telescope. No other RCs on the market are equipped with these versatile top-side universal mounting bars.

Mounting the Telescope

Orion Ritchey-Chretien astrographs each have a dovetail mounting bar running the full length of the optical tube for rigid attachment to a compatible equatorial mount saddle plate. The 6" RC has a narrow, Vixen-style bar while the 8" and 10" include a wide, Losmandy-style bar. The long length of the dovetail bars makes it easy to balance the RC on the declination axis by sliding the scope forward or back before locking it down.

Cooling the Telescope

Before observing or photographing with your RC, you should let it equilibrate to the outdoor temperature for an hour or more. This will reduce thermal air currents inside the telescope that could soften or blur your images, whether you're doing visual observing or astrophotography. Due to the size of its optics, the 10" RC is equipped with three small DC cooling fans on its rear cell to help accelerate the cool-down time (**Figure 8**). The fans pull outside air in through the rear cell and blow it

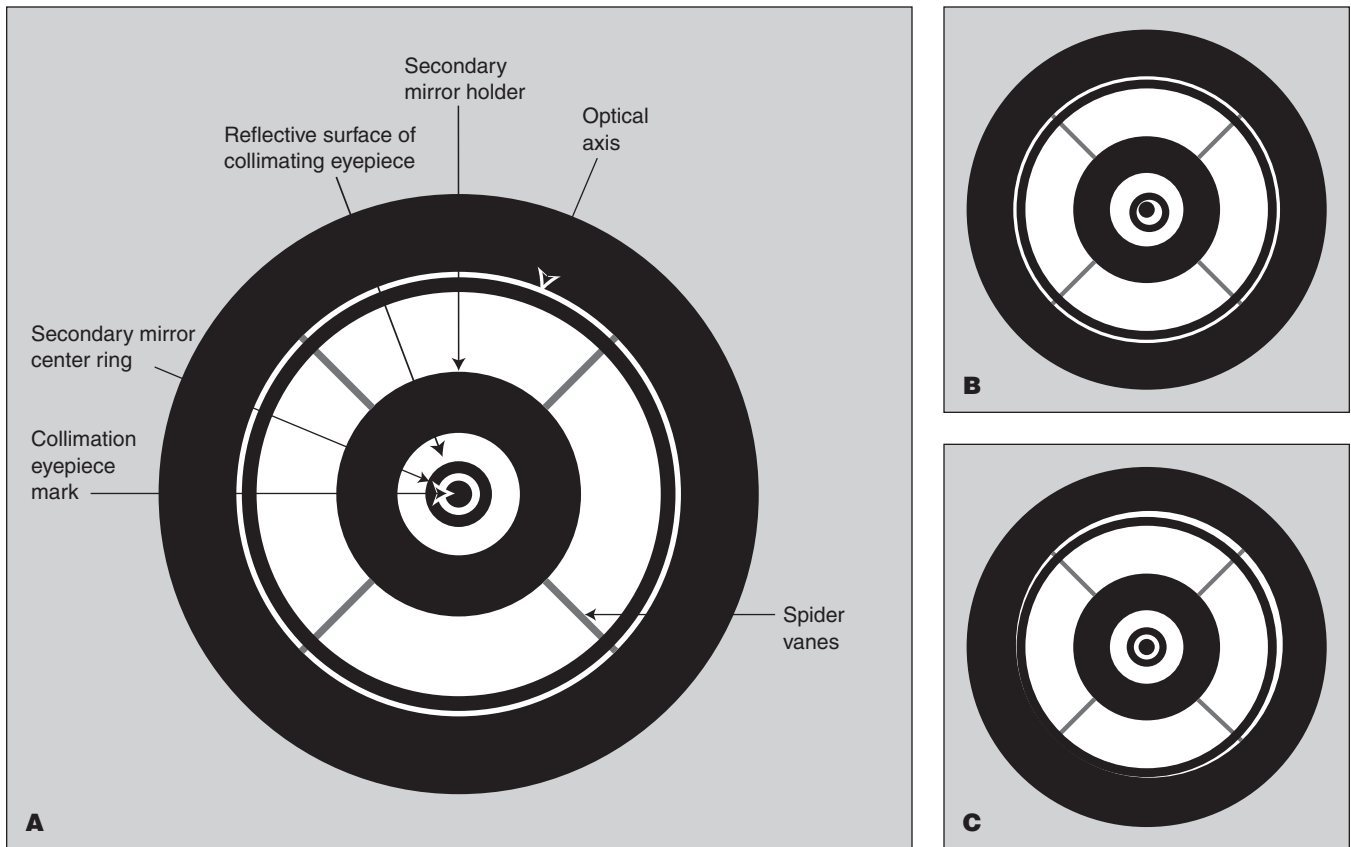

Figure 9. The view through a collimating eyepiece (not to scale). A) Shows the Ritchey-Chrétien aligned with all components identified. B) Shows the secondary out of alignment. C) Shows the optical axis out of alignment.

onto the back of the primary mirror and out the front of the telescope. It's best to point the telescope upward when the fans are on to allow the heat to more efficiently escape.

The fans require a 12V power supply; a battery holder is included with the 10" RC that accepts eight user-supplied AA batteries. The cable from the battery holder plugs into the DC power jack on the rear cell (**Figure 8**). The fans start up as soon as the power pack is plugged in; there is no ON/OFF switch. Alternatively, the fans can be powered by a 12V DC field battery that has a 5mm/2.1mm plug.

Although the fans are a low-vibration model, we recommend turning them off while actively observing or imaging to avoid any effect on the view from vibration or blowing air.

Collimating the Ritchey-Chrétien

The optics in your new Ritchey-Chrétien optical tube have been aligned at the factory. However, rough handling during transit may warrant periodic re-adjustments. We have precisely center marked the secondary mirror with a small adhesive ring to aid in collimation. This ring does not affect the view through the telescope, so it should not be removed. You will need a Cheshire eyepiece to check and adjust collimation. We recommend doing the collimation during daytime; it can be done indoors.

1. Remove any extension rings and attach the focuser directly to the optical tube.

2. Set up your telescope in a well-lit room with the telescope oriented horizontally, and point it at a light colored wall.

3. Insert the Cheshire eyepiece into the focuser via the included 1.25" adapter and tighten the thumbscrew on the adapter. Make sure that a bright source of light, like a ceiling light or flashlight, is aimed at the 45° reflecting surface of the Cheshire.

4. Look through the Cheshire eyepiece. You should see a small black dot and a dark ring within a larger bright circle. The dot is the hole of your Cheshire eyepiece. The dark ring is the center mark on the secondary mirror. And the bright circle is the reflective 45-degree surface of the Cheshire. The larger black circle outside that is the secondary mirror holder (**Figure 9A**).

If your scope is in good collimation, the black dot will be dead center in the dark ring, which will in turn be centered in the bright circle. If that's the case, no further adjustments to the secondary mirror will be necessary. The optical axis is denoted by a thin white circle on the outer edge. You can disregard that for the time being; it will be covered in the following section.

If the view looks something like **Figure 9B** — with the dot of the collimation eyepiece NOT centered in the secondary center ring — you will need to adjust the three collimation set-

screws at the front of the secondary mirror holder (**Figure 10**). This will adjust the tilt of the secondary, changing the relative position of the secondary center ring when peering through the collimation eyepiece.

Secondary Mirror Adjustment

NOTE: Only adjust the three screws around the perimeter of the holder—do not adjust the center screw! (Figure 10). Adjusting the center screw can cause the secondary mirror to fall off and will not be covered under warranty.

A 4mm hex key is required to perform collimation on the secondary mirror. When adjusting one of these screws you will need to make counter-adjustments to the other two. Therefore, if you are loosening one screw you will need to tighten the other two. At the end of the process you want all three collimation screws to be reasonably tight so the secondary mirror won't shift while the scope is in use.

Always start by loosening one screw. Adjust the screws only very slightly—by no more than 1/10 turn at a time, and one screw at a time before checking the view through the Cheshire again to see how things changed. Only tiny adjustments should be required to achieve collimation. This will also aid in the prevention of accidentally putting the telescope grossly out of collimation. With each tiny tweak of a screw, make a mental note of which way and how far the center dot moved, as that will inform which screw to turn next and by how much. Experiment with different combinations of loosening/tightening the three screws one by one until the collimation eyepiece's black dot is centered in the dark ring of the secondary mirror. The correct alignment of the secondary mirror is critical in determining if the optical axis requires alignment. Be sure you have properly aligned the secondary mirror before proceeding to the next step.

Optical Axis (Primary Mirror) Adjustment

The optical axis is denoted by a thin outline of light (white) around the perimeter of the view through the collimating eyepiece (**Figure 9A**). If this outline is not a perfect circle of uniform thickness, as in **9C**, that's an indication that the optical

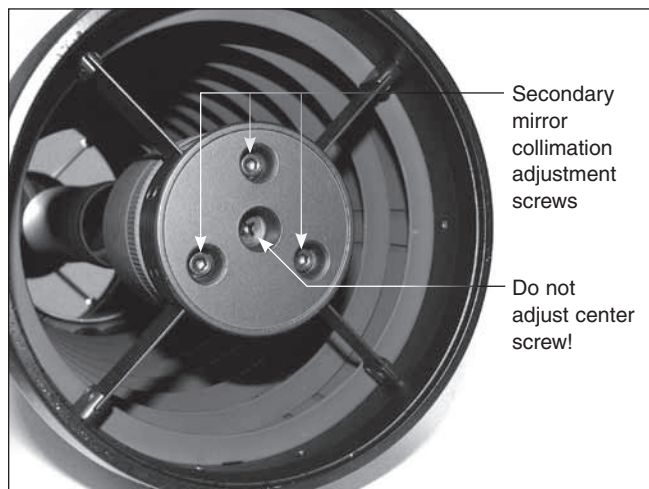

Figure 10. The secondary mirror collimation adjustment screws. A 4mm hex key is required.

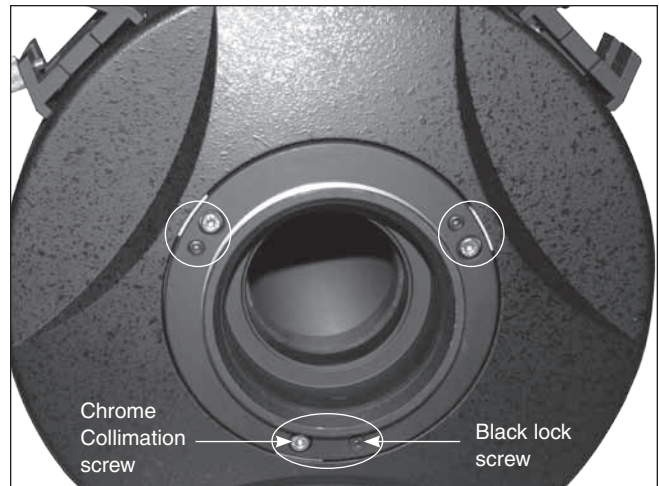

Figure 11: Three pairs of collimation screws on the rear cell allow adjustment of the optical axis, if needed. (8" RC shown)

axis (primary mirror) needs adjustment. This adjustment will require 3mm and 2.5mm hex keys for the 6" and 8" RCs, and 4mm and 2.5mm hex keys for the 10" RC.

Note that there are three pairs of screws on the rear cell of the optical tube where the focuser attaches (**Figure 11**). Each pair consists of a small black screw and a larger chrome screw. The small black screws are merely locking screws, which you should loosen before adjusting the mirror's tilt. The larger chrome screws are spring-loaded collimation screws that actually adjust the tilt of the primary mirror. Turn these collimation screws only a fraction of a turn at a time. Turn one and check the view through the Cheshire to see if it improved the white optical axis ring. Keep tweaking the collimation screws, each time checking the optical axis ring, until it is concentric and uniform in width. Then tighten the three lock setscrews to fix the mirror in that position.

After adjusting the optical axis, re-check the collimation of the secondary mirror and make any necessary adjustments, then recheck the optical axis collimation. Optical axis collimation will not need to be performed very often, if ever.

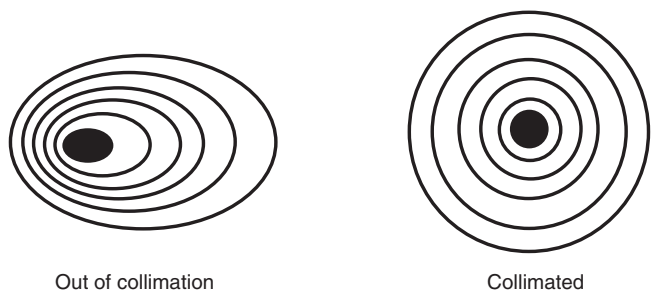

Figure 12. A de-focused view of a bright star through an eyepiece. Proper collimation will show concentric, symmetrical diffraction rings with a dark spot exactly in the center, as in the image on the right. If the spot is off-center, the scope needs collimation.

Star Testing

A star test can be performed to confirm the collimation accuracy of the telescope. The adjustment procedure on the telescope is the same as described above; testing, however, will be done in the night sky using a real star and you will not use the Cheshire eyepiece.

Choose a star close to the zenith (straight overhead) rather than at the horizon to minimize atmospheric distortions. Using Polaris as your target star can be helpful as minimal drift adjustments will be required.

Do not use a star diagonal while performing this procedure. Rather, place an eyepiece directly into the 1.25" adapter in the focuser. It should be an eyepiece that provides moderate to high magnification. You may need to add all three of the extension rings in front of the focuser to be able to reach focus. Center the star in the field of view. Slowly de-focus the image with the focusing knob until you can see a series of concentric diffraction rings form around the dark disk in the center. That dark disk is the shadow of the secondary mirror. In a well collimated telescope, the diffraction rings should appear round and concentric, with the dark disk exactly in the center (**Figure 12**). If the dark central disk is off center, the scope is out of collimation. Adjust the collimation of the secondary mirror and, only if necessary, the primary mirror while monitoring the defocused star until the dark central disk is exactly centered in the diffraction rings.

NOTE: It is important when checking or adjusting the collimation using a star, that the star be positioned in the center of the eyepiece's field of view. If it isn't, the optics will always appear out of collimation, even though they may be perfectly aligned! It is critical to keep the star centered, so over time you may need to make slight corrections to the telescope's position.

Care and Cleaning of the Optics

Do not disassemble the Ritchey-Chrétien for any reason, including to clean the mirror. A small amount of dust and particulates on the mirror's surface will not affect performance. In the event internal cleaning is necessary the telescope should be shipped to Orion Telescopes and Binoculars for service. This telescope does not contain user-serviceable parts and disassembly of the components will void the warranty. When not in use, please use the supplied dust cap(s) to keep dust and particulates out of the tube and off the optics.

Specifications

6" Ritchey-Chrétien

Aperture:	6" (150mm)
Focal Length	1370 mm
Focal Ratio	f/9
Mirror figure:	Hyperbolic
Mirror material	BK-7
Mirror Coating	Enhanced, 94%-96% reflectivity with SiO ₂ overcoat
Optical Tube	Steel
Focuser	2" Crayford, dual speed (10:1)
Drawtube travel:	34mm
Backfocus distance:	240.1mm from rear cell; 151.3mm from 2" collar on drawtube
Central obstruction:	72mm
Tube Length:	486mm
Tube Diameter:	191mm
Bottom mounting bar:	V-style (narrow)
Top mounting bar:	None
Cooling fans:	None
Weight:	12.1 lbs.

8" Ritchey-Chrétien

Aperture:	8" (200mm)
Focal length:	1600mm
Focal ratio:	f/8
Mirror figure:	Hyperbolic
Mirror material:	Fused quartz
Mirror Coating:	Enhanced, 94%-96% reflectivity with SiO ₂ overcoat
Optical Tube:	Steel
Focuser:	2" Linear-bearing Crayford, dual speed (10:1)
Drawtube travel:	50mm
Backfocus distance:	238.1mm from rear cell; 140.7mm from 2" collar on drawtube
Central obstruction:	95mm
Tube Length:	559mm
Tube Diameter:	232mm
Bottom mounting bar:	L-style (wide)
Top mounting bar:	V-style (narrow), slotted
Cooling fans:	None
Weight:	18.5 lbs.

10" Ritchey-Chrétien

Aperture:	10" (250mm)
Focal length:	2000mm
Focal ratio:	f/8
Mirror figure:	Hyperbolic
Mirror material:	Fused quartz
Mirror Coating:	Enhanced, 94%-96% reflectivity with SiO ₂ overcoat
Optical Tube:	Steel
Focuser:	3.3" Linear-bearing Crayford, dual speed (10:1)
Drawtube travel:	50mm
Backfocus distance:	243.9mm from rear cell; 139.6mm from 2" collar on drawtube
Central obstruction:	110mm
Tube Length:	721mm
Tube Diameter:	299mm
Bottom mounting bar:	L-style (wide)
Top mounting bar:	L-style, slotted
Cooling fans:	3 built-in fans, powered by 12V DC
Weight:	35.3 lbs.

One-Year Limited Warranty

This Orion product is warranted against defects in materials or workmanship for a period of one year from the date of purchase. This warranty is for the benefit of the original retail purchaser only. During this warranty period Orion Telescopes & Binoculars will repair or replace, at Orion's option, any warranted instrument that proves to be defective, provided it is returned postage paid. Proof of purchase (such as a copy of the original receipt) is required. This warranty is only valid in the country of purchase.

This warranty does not apply if, in Orion's judgment, the instrument has been abused, mishandled, or modified, nor does it apply to normal wear and tear. This warranty gives you specific legal rights. It is not intended to remove or restrict your other legal rights under applicable local consumer law; your state or national statutory consumer rights governing the sale of consumer goods remain fully applicable.

For further warranty information, please visit www.OrionTelescopes.com/warranty.

Orion Telescopes & Binoculars
Corporate Offices: 89 Hangar Way, Watsonville CA 95076 - USA

Customer Support: www.OrionTelescopes.com/contactus

Copyright © 2015 Orion Telescopes & Binoculars
All Rights Reserved. No part of this product instruction or any of its contents may be reproduced, copied, modified or adapted, without the prior written consent of Orion Telescopes & Binoculars.