

# Instruction Manual

## StarNavigator NG Series Telescopes with AudioStar®



MEADE.COM



**MEADE®**



# WARNING!

**Never use a Meade<sup>®</sup> StarNavigator NG<sup>™</sup> Telescope to look at the Sun!** Looking at or near the Sun will cause instant and irreversible damage to your eye. Eye damage is often painless, so there is no warning to the observer that damage has occurred until it is too late. Do not point the telescope at or near the Sun. Do not look through the telescope or viewfinder as it is moving. Children should always have adult supervision while observing.

**Refracting Telescopes** use a large objective lens as their primary light-collecting element. Meade refractors, in all models and apertures, include achromatic (2-element) objective lenses in order to reduce or virtually eliminate the false color (chromatic aberration) that results in the telescopic image when light passes through a lens.

**Reflecting Telescopes** use a concave primary mirror to collect light and form an image. In the Newtonian type of reflector, light is reflected by a small, flat secondary mirror to the side of the main tube for observation of the image.

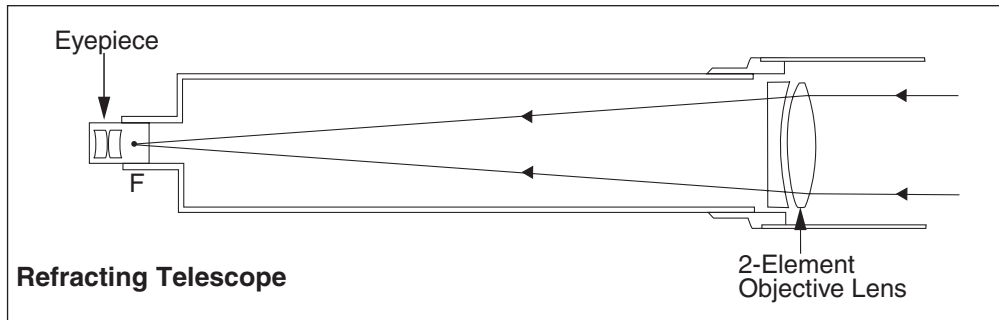

In the refracting telescope, light is collected by a 2-element objective lens and brought to a focus at F.

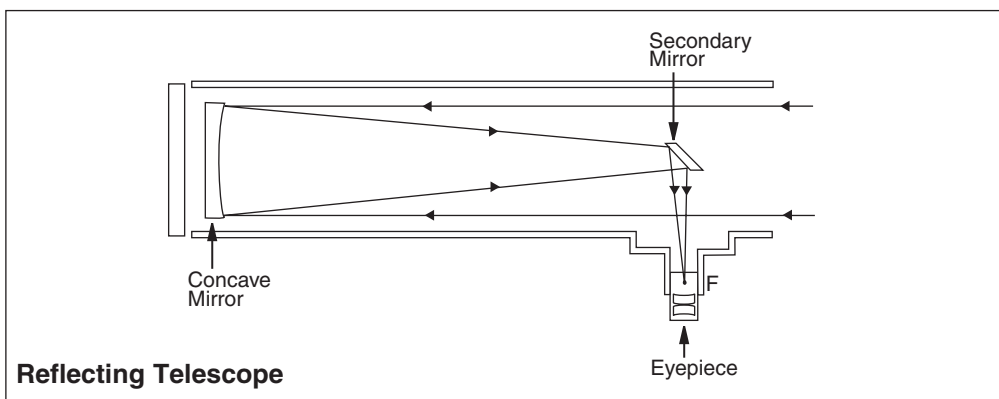

In contrast, the reflecting telescope uses a concave mirror for this purpose.

**Battery Safety Instructions**

- Always purchase the correct size (8 x 1.5V AA, 15A/15AC ANSI, LR6 IEC), (2 x ANSI/NEDA-5004LC, IEC-CR2032) and grade of battery most suitable for the intended use.
- Replace all batteries of a set at the same time.
- Clean the battery contacts and also those of the device prior to battery installation.
- Ensure the batteries are installed correctly with regard to polarity (+ and -).
- Remove the batteries from any telescope which is not to be used for an extended period of time.
- Remove used batteries promptly.
- Do not mix old batteries with new batteries.
- Do not mix alkaline, standard (Carbon Zinc), or rechargeable (Nickel Cadmium) batteries.

**Caution:**

- If batteries or parts are swallowed, see a doctor immediately.

**If you are anxious to use your StarNavigator NG Telescope for the first time, before a thorough reading of this instruction manual, see the QUICK-START GUIDE on page 4.**

© The name "Meade," "AudioStar," and the Meade logo are trademarks registered with the U.S. Patent Office and in principal countries throughout the world. All rights reserved.

™ "LPI" and "Tonight's Best" are trademarks of Meade Instruments Corporation.

Patents:  
US 6,392,799  
Other Patent Pending

© 2016 Meade Instruments Corporation. All rights reserved.  
Specifications subject to change without notice.

**CONTENTS**

Quick-Start Guide ..... 4

Refracting Telescope Features ..... 7

Reflecting Telescope Features ..... 9

AudioStar Features ..... 12

Getting Started ..... 14

    Packing List..... 14

    How to Assemble Your Telescope ..... 14

    Red Dot Viewfinder ..... 15

        Aligning the Viewfinder..... 15

        Choosing an Eyepiece..... 16

Observing ..... 17

    Observing by Moving the Telescope Manually ..... 17

    Terrestrial Observing ..... 17

    Observing Using AudioStar's Arrow Keys ..... 17

    Slew Speeds ..... 18

    Playing the Audio ..... 18

    Observe the Moon ..... 19

    Astronomical Observing..... 19

    To Track an Object Automatically..... 19

        Alt/Az Home Position..... 19

        Moving Through AudioStar's Menus ..... 19

        Initializing AudioStar ..... 19

        Observe a Star Using Automatic Tracking ..... 20

    Easy (Two-Star) Align ..... 21

    Two-Star Alt/Az Alignment..... 22

    One-Star Alt/Az Alignment..... 22

    Go To Saturn ..... 22

    Take a Guided Tour..... 22

Basic AudioStar Operation ..... 23

    AudioStar Navigation Exercise ..... 24

    Entering Numbers and Text into AudioStar ..... 24

    Navigating AudioStar ..... 24

    Adjusting the Speed of a Scrolling Message..... 24

Menus and Menu Options ..... 25

    Object Menu..... 25

    Event Menu..... 25

    Complete AudioStar Menu Structure ..... 26

    Glossary Menu, Utilities Menu ..... 27

    Setup Menu..... 28

Helpful Hints about Getting Started..... 31

Advanced AudioStar Features ..... 32

    Adding Observing Sites ..... 32

    Writing Your Own Guided Tour ..... 33

    Landmarks ..... 36

    Identify ..... 37

    Browse ..... 38

Optional Accessories..... 39

Caring for Your Telescope ..... 40

    Collimation ..... 40

    Meade Consumer Solutions ..... 42

Specifications ..... 43

Appendix A: Celestial Coordinates..... 45

    Locating the Celestial Pole ..... 45

Appendix B: To Find Objects Not in the Database ..... 46

Appendix C: Observing Satellites..... 47

Appendix D: Training the Drive ..... 48

Appendix E: Red Dot - Replacing the Battery..... 49

Appendix F: Manually Setting Time and Date..... 49

Basic Astronomy ..... 50

Meade Limited Warranty ..... Back Cover

# QUICK-START GUIDE

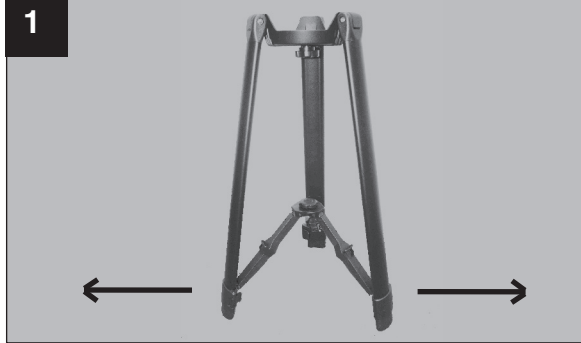

1. **Open the tripod:** Remove the tripod from the giftbox and stand vertically. Gently pull the legs apart to a fully open position. Attach the accessory tray to the tripod by threading the center bolt into the tray until firm.



2. **Attach the mounting arm assembly:** Place the mounting arm assembly into the tripod base. Reach underneath and thread the mounting knob through the tripod base and into the mounting arm assembly. Tighten to a firm feel only, do not overtighten. While observing, you may wish to slightly loosen this knob and rotate the mounting arm assembly with attached optical tube around the horizontal axis.



3. **Attach the optical tube assembly to the base/mounting arm assembly:** The optical tube assembly is shipped with the vixen style dovetail plate attached. Slide the OTA onto dovetail plate and tighten the locking screw.



4. **Attach and balance the optical tube:** Tighten the DEC lock knob so that it holds the optical tube loosely. Slide the tube back and forth until you find a position where the tube remains horizontal (i.e., without tipping up and down). Tighten the cradle rings lock knob to a firm feel.

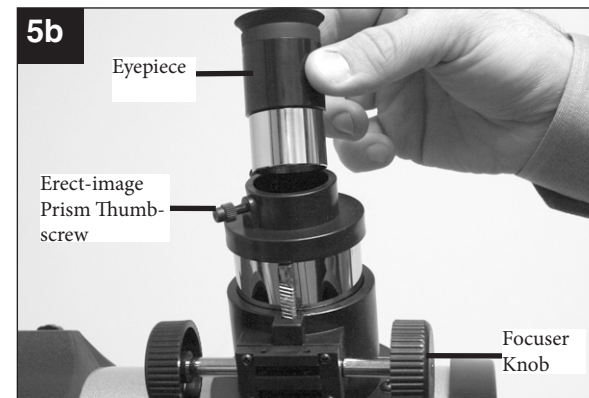
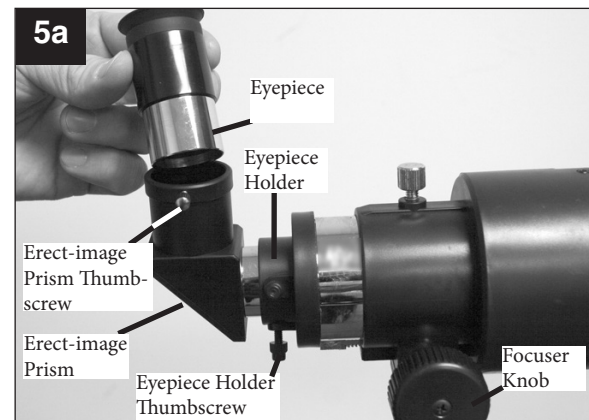

- 5a. **Attach the 90° Erect-Image Prism (refractor models only, see inside front cover):** Pull out to remove the plastic dust cover from the eyepiece holder. Slide the tube of the erect-image prism into the telescope's eyepiece-holder and tighten the thumbscrews to a firm feel only to secure.

 Looking at or near the **Sun** will cause **irreversible** damage to your eye. Do not point this telescope at or near the Sun. Do not look through the telescope as it is moving.

5b. **Insert the eyepiece:** Remove the supplied 26mm eyepiece from its container and place it in the erect-image prism (*refractor models only*; see **Fig. 5a**) or directly into the eyepiece holder (*reflector models only*; see **Fig. 5b**). Tighten the thumbscrews to a firm feel only. Remove the dust cover from the end of optical tube assembly. Use the focus knobs to bring objects into focus.

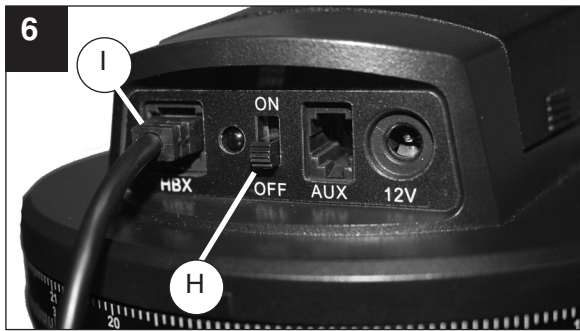

6. **Connect AudioStar:** Be certain that the power switch (H) on the computer control panel is in the OFF position. Plug the coil cord of the AudioStar Controller into the HBX port (I). When turning on the control panel; the red LED will light up when power is supplied to the panel.



7. **Power on the Telescope:** Open the battery compartment by lifting the cover and pulling it away from the drive base.

Remove the battery holder from the compartment and carefully lift the 9v connector out from the compartment. Whenever you replace the batteries, to safeguard the wires, disconnect the 9v connector (G) from the battery holder before removing the batteries.

Insert eight AA-size batteries into the battery holder, oriented as shown on the diagram on the battery slots of the battery holder. Connect the 9v connector plug to the battery holder. Carefully replace the battery holder back into the battery compartment. Replace the cover.

If you have the optional AC adapter (07584) plug the adapter into any 12v wall socket and plug the other end into the power port of the control base and flip the switch on.

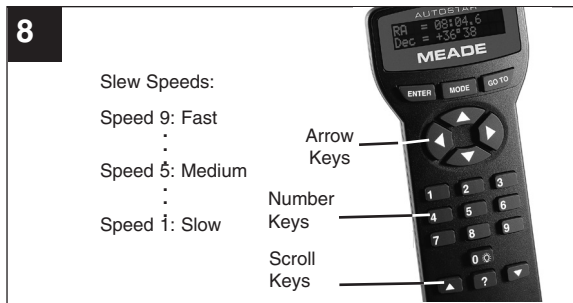

8. You can use the Arrow keys to slew (move) the telescope up, down, right, or left. To change the telescope's slew speed, press a Number key. "9" is the fastest speed and "1" is the slowest speed. See pages 18 for more details.

For scrolling AudioStar text, press and hold the Scroll Up key to increase the scrolling speed when a message is scrolling across the display. Press and hold the Scroll Down key to decrease the scrolling speed when a message is scrolling across the display.



9. **Sight along the tube:** Sight along the side of the telescope's main tube to locate an object. Practice using the AudioStar Arrow keys to center an object in the telescope's field of view.

**If you wish to attach the red dot viewfinder, see page 15.**  
**If you wish to initialize AudioStar, see page 19.**  
**If you wish to align the telescope, go to page 21.**  
**If you wish to use AudioStar to GO TO Saturn, go to page 22.**

# REFRACTING TELESCOPE FEATURES

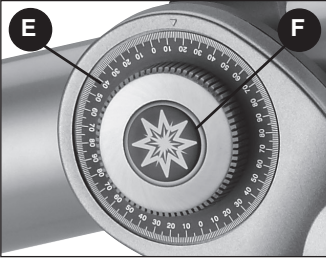

Fig. 1b (Inset): (E) Altitude Setting Circle; (F) Altitude Lock.



Fig. 1d (Inset): Compass/Bubble Level.

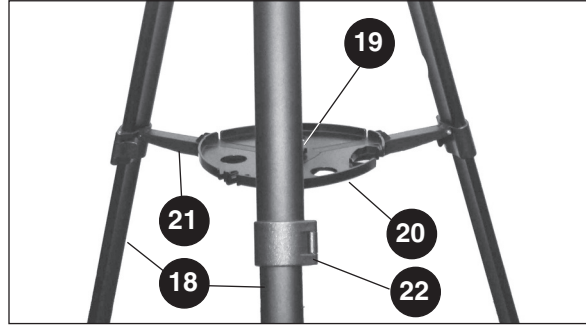
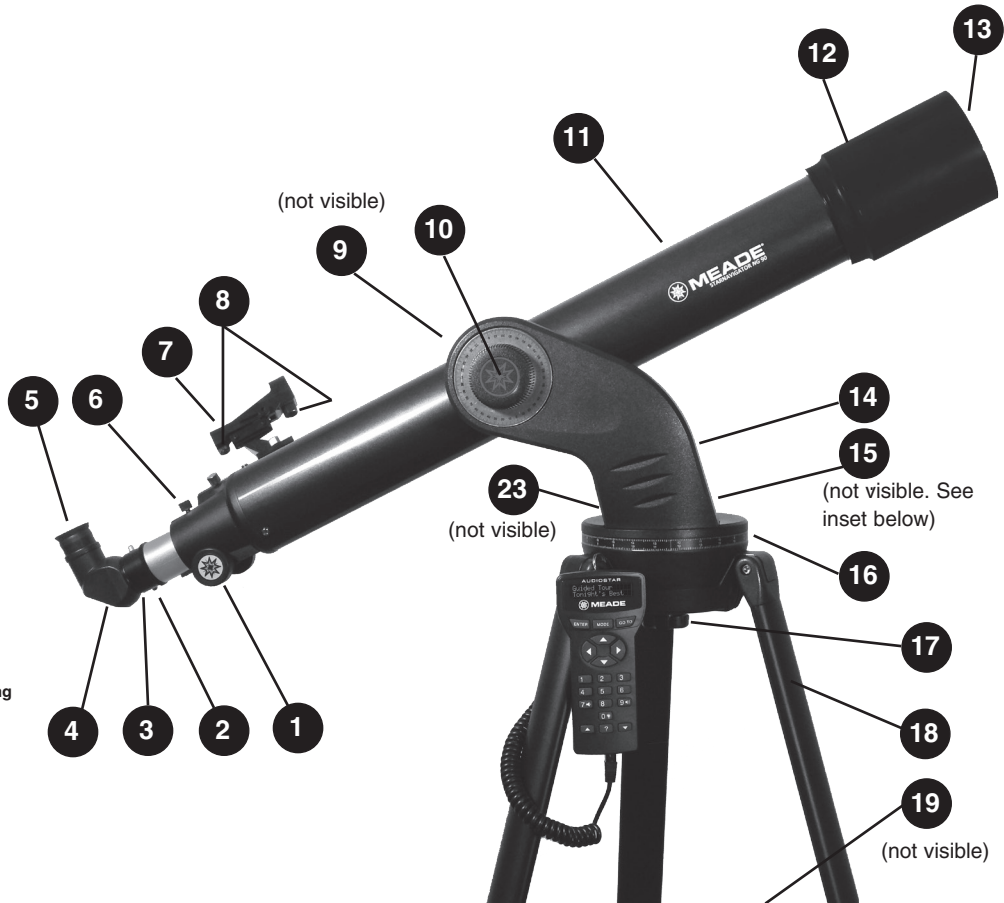

Fig. 1e (Inset): Tripod Assembly.

1. Focus Knob
2. Eyepiece Holder Thumbscrew
3. Eyepiece Holder
4. 90° Erect-Image Prism
5. Eyepiece
6. Focus Lock Knob
7. Red Dot Viewfinder
8. Red Dot Viewfinder Alignment Screw
9. Dovetail Receiver (Not Visible)
10. Altitude Setting Circle and Lock
11. Optical Tube (OTA)
12. Dew Shield
13. Dust Cap (Not Shown)
14. Mount Body
15. Control Panel
16. Azimuth Setting Circle
17. Tripod Base with Mounting Knob
18. Tripod Leg
19. Accessory Tray Mounting Screw
20. Accessory Tray
21. Inner Support Struts
22. Tripod Leg Locks
23. Battery Compartment



Features of the StarNavigator NG Series telescopes are virtually identical. Certain features of your telescope may look different than, or be positioned slightly different than the one pictured here, but the functionality of the features is the same.



Fig. 1c (Inset): Computer Control Panel. (A) Handbox port; (B) Power indicator light, (C) ON switch; (D) Auxiliary port; (E) 12v Power.

Fig. 1a: StarNavigator NG Refracting Telescope.



Looking at or near the **Sun** will cause **irreversible** damage to your eye. Do not point this telescope at or near the Sun. Do not look through the telescope as it is moving.

# REFRACTING TELESCOPE FEATURES

Take the time to become acquainted with your refracting telescope and all of these controls before attempting observations through the telescope. Refer to Figure 1a.

1. **Focus Knob:** Moves the telescope's focus drawtube in a finely-controlled motion to achieve precise image focus. Rotate the focus knob clockwise to focus on distant objects, and counterclockwise to focus on nearby objects.
2. **Eyepiece Holder Thumbscrew:** Tightens the eyepiece in place. Tighten to a firm feel only.
3. **Eyepiece Holder:** Holds the 90° Erect-Image Prism in place.
4. **90° Erect-Image Prism:** Holds the eyepiece upright for easy viewing and correctly orients the image.
5. **Eyepiece:** Place the supplied eyepiece into the 90° Erect-Image Prism and tighten in place with thumbscrew.
6. **Focus Lock Knob:** Designed to prevent the focuser drawtube from moving when a heavy accessory, such as a camera, is attached to the focuser assembly. For normal observing with an eyepiece and erect-image prism, it is not necessary to use the lock knob.
7. **Red Dot Viewfinder:** Provides an easier way to initially sight objects than the main telescope eyepiece which has a narrower field of view. Rotate the knob on the front of the red dot viewfinder to turn on the device and to change the intensity of the red dot.
8. **Red Dot Viewfinder Alignment Screws:** Adjust these screws to align the viewfinder. See page 15 for more information.
9. **Dovetail Receiver (not visible):** Attaches the optical tube to the mount and secures it in place with a single locking screw.
10. **Altitude Setting Circle and Lock:** The setting circle displays Altitude (vertical) coordinates (E, Fig. 1b). The Altitude Lock controls the manual vertical movement of the telescope. Turning the Altitude lock counterclockwise unlocks the telescope enabling it to be freely tilted by hand on the vertical axis. Turning the Altitude lock clockwise (to a firm feel only) prevents the telescope from being moved manually and engages the vertical motor drive clutch for AudioStar operation (F, Fig. 1b).
11. **Optical Tube Assembly (OTA):** The main optical component that gathers the light from distant objects and brings this light to a focus for observation with the eyepiece.
12. **Dew Shield:** Reduces dew formation on the telescope's primary lens.
13. **Dust Cap:** Pull to remove the dust cap from the front lens of the telescope.  
  
Note: The dust cap should be replaced and the power turned off to the telescope after each observing session. Verify that any dew that might have collected during the observing session has evaporated before replacing the dust cap.
14. **Mount Body:** Holds the optical tube assembly. Attaches to the tripod base (17, Fig. 1).
15. **Computer Control Panel (Fig. 1 c)**
  - A. **Hand box (HBX) Port:** Plug the AudioStar hand box
  - B. **LED:** The red power indicator light illuminates when power is supplied to the connected hand box and to the telescope's motor drive.



Looking at or near the **Sun** will cause **irreversible** damage to your eye. Do not point this telescope at or near the Sun. Do not look through the telescope as it is moving.

**C. ON Switch:** Press to turn the Computer Control Panel and AudioStar ON or OFF.  
Note: Always remove the batteries if they are not to be used for a long period of time.

**D. Auxiliary (AUX) Port:** Provides connection for current and future Meade accessories. See OPTIONAL ACCESSORIES, page 39.

**E. 12 Volt Power Port:** Provides connection for the 07584 Meade Universal 12 volt AC Adapter.

16. **Azimuth Setting Circle:** Displays Azimuth (horizontal) coordinates.
17. **Tripod Base with Mounting Knob.** - Attaches the mount body (14, Fig 1) to tripod base. Loosen before manually moving the optical tube on the horizontal axis. Tighten this knob to a firm feel when using the AudioStar handbox to move the telescope.
18. **Tripod Legs** - Spread the legs out as far as they will open for a secure viewing platform.
19. **Accessory Tray Mounting Bolt** – Attaches Accessory tray to the tripod.
20. **Accessory Tray** - Conveniently holds extra eyepieces, AudioStar hand box, and other accessories.
21. **Inner Support Struts (3)** - Make the tripod more secure and stable.
22. **Tripod Legs Locks (3)** - Lift the lock up to loosen inner section of a tripod leg and extend the inner leg to desired height. Press the lock down to lock the leg in place.
23. **Battery Compartment** - Install eight user-supplied AA batteries in this compartment. See page 14 for more information.



Looking at or near the **Sun** will cause **irreversible** damage to your eye. Do not point this telescope at or near the Sun. Do not look through the telescope as it is moving.



# REFLECTING TELESCOPE FEATURES

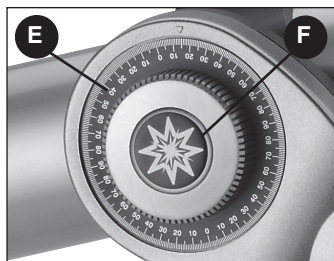

Fig. 2b (Inset): (E) Altitude Setting Circle; (F) Altitude Lock.



Fig. 2d (Inset): Compass/Bubble Level.

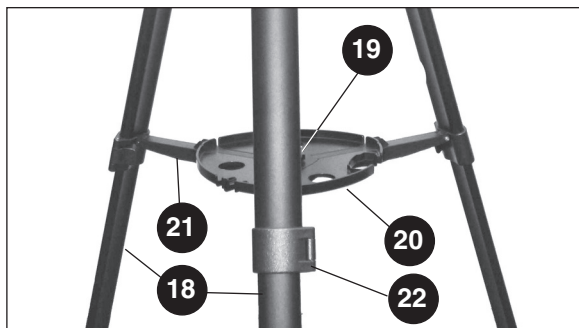

Fig. 2e (Inset): Tripod Assembly.

1. Focus Knob
2. Eyepiece Holder Thumbscrew
3. Eyepiece Holder
4. Primary Mirror Collimation Adjustment Screws
5. Eyepiece
6. Focus Lock Knob
7. Red Dot Viewfinder
8. Red Dot Viewfinder Alignment Screw
9. Dovetail Receiver (Not Visible)
10. Altitude Setting Circle and Lock
11. Optical Tube (OTA)
12. Secondary Mirror Collimation Adjustment Screws (not visible)
13. Dust Cap
14. Mount Body
15. Control Panel (not visible. See inset below)
16. Azimuth Setting Circle
17. Tripod Base with Mounting Knob
18. Tripod Leg
19. Accessory Tray Mounting Screw (not visible)
20. Accessory Tray
21. Inner Support Struts
22. Tripod Leg Locks
23. Battery Compartment (not visible)

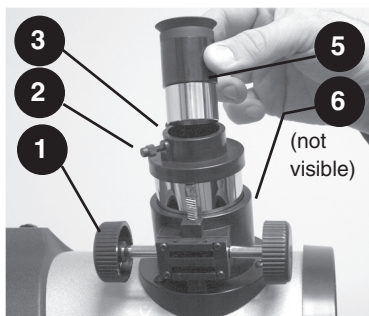

Fig. 2f (Inset): Focuser Assembly.

Features of the StarNavigator NG Series telescopes are virtually identical. Certain features of your telescope may look different than, or be positioned slightly different than the one pictured here, but the functionality of the features is the same.

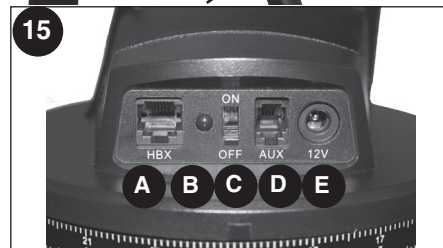

Fig. 2c (Inset): Computer Control Panel. (A) Handbox port; (B) Power indicator light, (C) ON switch; (D) Auxiliary port; (E) 12v Power.

Fig. 2a: StarNavigator NG Reflecting Telescope.

 Looking at or near the **Sun** will cause **irreversible** damage to your eye. Do not point this telescope at or near the Sun. Do not look through the telescope as it is moving.

# REFLECTING TELESCOPE FEATURES

Take the time to become acquainted with your reflecting telescope and all of these controls before attempting observations through the telescope. Refer to Figure 2a.

1. **Focus Knob:** Moves the telescope's focus drawtube in a finely-controlled motion to achieve precise image focus. Rotate the focus knob clockwise to focus on distant objects, and counterclockwise to focus on near-by objects.
2. **Eyepiece Holder Thumbscrew:** Tightens the eyepiece in place. Tighten to a firm feel only.
3. **Eyepiece Holder:** Holds the eyepiece in place.
4. **Primary Mirror Collimation Adjustment Screws:** Adjustment and locking screws for tipping and tilting the primary mirror. See page 40 for more information.
5. **Eyepiece:** Place the supplied eyepiece into the Eyepiece Holder and tighten in place with the thumbscrew.
6. **Focus Lock Knob:** Designed to prevent the focuser drawtube from moving when a heavy accessory, such as a camera, is attached to the focuser assembly. For normal observing with an eyepiece it is not necessary to use the lock knob.
7. **Red Dot Viewfinder:** Provides an easier way to initially sight objects than the main telescope eyepiece which has a narrower field of view. Rotate the knob on the front of the red dot viewfinder to turn on the device and to change the intensity of the red dot.
8. **Red Dot Viewfinder Alignment Screws:** Adjust these screws to align the viewfinder. See page 15 for more information.
9. **Dovetail Receiver:** Attaches the optical tube to the mount and secures it in place with a single locking screw.
10. **Altitude Setting Circle and Lock:** The setting circle displays Altitude (vertical) coordinates (E, Fig. 2b). The Altitude Lock controls the manual vertical movement of the telescope. Turning the Altitude lock counterclockwise unlocks the telescope enabling it to be freely tilted by hand on the vertical axis. Turning the Altitude lock clockwise (to a firm feel only) prevents the telescope from being moved manually and engages the vertical motor drive clutch for AudioStar operation (F, Fig. 2b).
11. **Optical Tube Assembly (OTA):** The main optical component that gathers the light from distant objects and brings this light to a focus for observation with the eyepiece.
12. **Secondary Mirror Collimation Adjustment Screws:** Adjustment screws for tipping and tilting the secondary mirror. See page 40 for more information.
13. **Dust Cap:** Pull to remove the dust cap from the front lens of the telescope.  
  
Note: The dust cap should be replaced and the power turned off to the telescope after each observing session. Verify that any dew that might have collected during the observing session has evaporated before replacing the dust cap.
14. **Mount Body:** Holds the optical tube assembly. Attaches to the tripod base (17, Fig. 2).
15. **Computer Control Panel (Fig. 2c)**
  - A. **Hand box (HBX) Port:** Plug the AudioStar hand box
  - B. **LED:** The red power indicator light illuminates when power is supplied to the connected hand box and to the telescope's motor drive.



Looking at or near the **Sun** will cause **irreversible** damage to your eye. Do not point this telescope at or near the Sun. Do not look through the telescope as it is moving.

**C. ON Switch:** Press to turn the Computer Control Panel and AudioStar ON or OFF.  
Note: Always remove the batteries if they are not to be used for a long period of time.

**D. Auxiliary (AUX) Port:** Provides connection for current and future Meade accessories. See OPTIONAL ACCESSORIES, page 39.

**E. 12 Volt Power Port:** Provides connection for the 07584 Meade Universal 12 Volt AC Adapter.

16. **Azimuth Setting Circle:** Displays Azimuth (horizontal) coordinates.
17. **Tripod Base with Mounting Knob.** - Attaches the mount body (14, Fig 2) to tripod base. Loosen before manually moving the optical tube on the horizontal axis. Tighten this knob to a firm feel when using the AudioStar handbox to move the telescope.
18. **Tripod Legs** - Spread the legs out as far as they will open for a secure viewing platform.
19. **Accessory Tray Mounting Bolt** – Attaches Accessory tray to the tripod.
20. **Accessory Tray** - Conveniently holds extra eyepieces, AudioStar hand box, and other accessories.
21. **Inner Support Struts (3)** - Make the tripod more secure and stable.
22. **Tripod Legs Locks (3)** - Lift the lock up to loosen inner section of a tripod leg and extend the inner leg to desired height. Press the lock down to lock the leg in place.
23. **Battery Compartment** - Install eight user-supplied AA batteries in this compartment. See page 14 for more information.



Looking at or near the **Sun** will cause **irreversible** damage to your eye. Do not point this telescope at or near the Sun. Do not look through the telescope as it is moving.

# AUDIOSTAR FEATURES

## Tour the Cosmos with Just the Push of a Button

Control your StarNavigator NG Series system with the standard-equipment AudioStar. Nearly all functions of the telescope are accomplished with just a few pushes of AudioStar's buttons. Some of the major features of AudioStar are:

- Automatically move the telescope to any of over 30,000 objects stored in the database or manually enter the astronomical coordinates of any celestial object.
- Listen to over 4 hours of pre-installed audio presentations about the night sky objects you are looking at thru the telescope.
- Take a guided tour of the best celestial objects to view on any given night of the year.
- Download the latest satellite, comet, astroid and handbox data using the Meade Autostar Updater program. (Requires optional Meade #505 Cable Connector Kit & the Meade USB to RS 232 (Serial) Adapter. See **OPTIONAL ACCESSORIES**, page 39.)
- Control your StarNavigator NG with your PC using an RS-232 interface. (Requires optional Meade #505 Cable Connector Kit & the Meade USB to RS 232 (Serial) Adapter. See **OPTIONAL ACCESSORIES**, page 39.)
- Access a glossary of astronomical terms.
- Calculate which eyepiece to use for optimum viewing of a celestial object.

**NOTE:** AudioStar does not require batteries; the telescope's batteries supply power to AudioStar.

AudioStar has soft-touch keys designed to have a positive feel. The LCD (Liquid Crystal Display) is backlit with a red LED (Light Emitting Diode) for easy viewing in the dark. The backlit display, key arrangement, and sequential database make AudioStar extremely user friendly.

b **2-Line LCD Display:** Provides an interface between AudioStar and the telescope.

- **Top line:** Lists the primary category or menu item.
- **Bottom line:** Contains a menu option or information about an object or subject, depending on which function is being performed.

c **ENTER Key:** Accesses, in a sequential manner, the next menu or data level in the AudioStar database. See **MOVING THROUGH AudioStar'S MENUS**, page 19 and **AUDIOSTAR'S MENU AND MENU OPTION DESCRIPTIONS**, page 26.

**NOTE:** If ENTER is pressed for two seconds or more and then released, AudioStar emits a beep and "ENTER to Sync" is displayed. "ENTER to Sync" is relevant only after the telescope has been aligned and is pointing at an object. If the "ENTER to Sync" feature is accessed by mistake, press MODE to return to the previous screen. See **HIGH PRECISION**, page 29, for more details about this feature.

d **MODE Key:** Returns to the previous menu or data level in the AudioStar database until the top level, "Select Item," is reached. The MODE key is similar to the ESCAPE key on a computer.

**NOTE:** Pressing MODE while in the "Select Item" level moves AudioStar to the topmost screen: "Select Item: Object."

**NOTE:** If MODE is pressed and held for two seconds or more, information about the telescope's status is then available using the Scroll keys (7, **Fig. 3**), such as:

- Right Ascension and Declination (astronomical) coordinates (see page 45)
  - Altitude (vertical) and Azimuth (horizontal) coordinates
  - Local Time and Local Sidereal Time (LST), Timer and Alarm Status
- Press MODE again to return to the previous menu.

e **GO TO Key:** Slews (moves) the telescope to the coordinates of the currently selected object. While the telescope is slewing, the operation may be aborted at any time by pressing any key except GO TO. Pressing GO TO again resumes the slew to the object.

f **Arrow Keys:** Slew the telescope in a specific direction (up, down, left, and right), at any one of nine different speeds. Speed selection is explained in **SLEW SPEEDS**, page 18. The following functions are also available with the Arrow keys:

- **Data Entry:** Use the Up and Down Arrow keys to scroll through the letters of the alphabet and numerical



Looking at or near the **Sun** will cause **irreversible** damage to your eye. Do not point this telescope at or near the Sun. Do not look through the telescope as it is moving.

digits. The Down Arrow key starts with the letter “A” and the Up Arrow key starts with the digit “9.” The Left and Right Arrow keys are used to move the blinking cursor left and right across the LCD display.

- **Alt/Az Alignment:** Use the Up and Down Arrow keys to move the telescope vertically up and down. The Left Arrow key rotates the telescope horizontally counterclockwise, while the Right Arrow key rotates it clockwise.
- g **Number Keys:** Input digits 0 - 9 and changes the slew speeds (see **SLEW SPEEDS**, page 18). The “0” key also turns on and off the red utility light on the top of the handbox.
- h **Scroll Keys:** Access database options within a selected menu. The menu is displayed on the first line of the screen. Options within the menu are displayed, one at a time, on the second line. Press the Scroll keys to move through the options. Press and hold a Scroll key to move quickly through the options. The Scroll keys also scroll through the letters of the alphabet and numerical digits.

**NOTE:** The Scroll Down key and the Down Arrow key move forward through the alphabet & digits (A to Z, 0 to 9). The Scroll Up key and the Up Arrow key move backward (Z to A, 9 to 0). Common symbols are also available in the list.

- i **? Key:** Accesses the “Help” file. “Help” provides on-screen information on how to accomplish whatever task is currently active.

Hold down the ? key and then follow the prompts on the display to access details of AudioStar functions in the Help feature. The Help system is essentially an on-screen instruction manual.

If you have a question about an AudioStar operation, *e.g.*, INITIALIZATION, ALIGNMENT, *etc.*, hold down the ? key and follow the directions that scroll on the second line of the LCD screen. When a word appears in [brackets], press ENTER to access the AudioStar Glossary. A definition or more detailed information is displayed. Press MODE to return to the scrolling AudioStar Help display.

When satisfied with the Help provided, press MODE to return to the original screen and continue with the chosen procedure.

- j **Coil Cord Port:** Plug one end of the AudioStar coil cord into this port (**11, Fig. 3**) located at the bottom of the AudioStar handbox.
- k **Coil Cord:** Plug one end of the AudioStar coil cord into the HBX port (**A, Fig. 1 or 2 C**) of the computer control panel of the telescope.
- l **RS-232 Port:** Plug an RS-232 cable into AudioStar for downloading functions such as “Download” or “Clone.” See page 30 for more details.
- m **Utility Light:** Use this built-in red light to illuminate star charts and accessories without disturbing your eye’s adaptation to darkness.



Fig. 3: The AudioStar Handbox.

 Looking at or near the Sun will cause irreversible damage to your eye. Do not point this telescope at or near the Sun. Do not look through the telescope as it is moving.

# GETTING STARTED

## DEFINITION:

Throughout this manual, you will notice the term “Alt/Az.” Alt/Az (short for *altazimuth*) just means that your telescope moves up and down and from side to side. Alt/Az is one of many methods used by amateur astronomers to locate celestial objects.

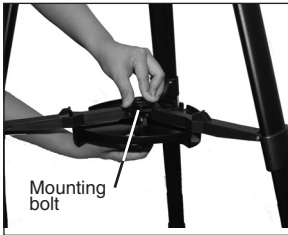

Fig. 4 Attach Tray to the tripod: Thread the mounting bolt into the accessory tray.

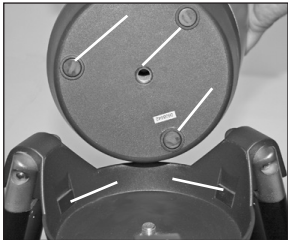

Fig. 5: Pads allow the mount to move smoothly.



Fig. 6: Attach the mounting arm to the tripod base.

## Packing List

Getting the telescope ready for first observations requires only a few minutes. When first opening the packing box, note carefully the parts listed on your giftbox.

## How to Assemble Your Telescope

The telescope attaches directly to the tripod. The telescope in this way is mounted in an “Altazimuth” (“Altitude-Azimuth,” or “vertical-horizontal”) format. The telescope in this configuration moves up and down and from side to side.

1. **Open the tripod:** After removing the field tripod from its shipping carton, stand the tripod vertically, with the tripod feet down and with the tripod still fully collapsed. Gently pull the legs apart to a fully open position.
2. **Attach the accessory tray to the tripod:** Place the tray (20, Fig. 1 or 2) under the inner support struts in the center. Line up the bolts holes on the accessory tray with the mounting bolt in the center of the struts. Tighten to a firm feel only.
3. **Three Pads:** There are three pads in the tripod base (17, Fig. 1 or 2) and three pads on the mounting arm assembly (14, Fig. 1 or 2). These pads allow the mounting arm assembly to move more easily inside the base. See Fig. 5. This is pointed out just for the user’s knowledge of the telescope; the user does not need to adjust the pads which are pre-installed.
4. **Attach the mounting arm assembly to the tripod base:** Place the mounting arm assembly into the tripod base and continue to hold onto the arm assembly. With your other hand, reach underneath the base and thread the mounting lock knob (17, Fig. 1 or 2) through the tripod base and into the mounting arm assembly. Tighten to a firm feel only; do not overtighten. If you wish to move the scope manually, without AudioStars assistance, loosen this knob and rotate the mounting arm assembly and optical tube on the horizontal axis. To use with AudioStar’s assistance, the mounting arm assembly will need to be tightened to a firm feel.
5. **Attach the Optical Tube Assembly to the tripod base:** The optical tube assembly comes with a vixen style dovetail that is attached to the OTA. While holding onto the arm assembly, with your other hand, slide the optical tube assembly into the dovetail saddle and (9, Fig. 1 or 2) tighten the locking screw to a firm feel only; do not overtighten.
6. **Attach and balance the optical tube:** Tighten the dovetail lock knob so that it holds the optical tube loosely. Slide the tube back and forth until you find a position where the tube remains horizontal (*i.e.*, without slightly tipping up or down). Tighten the lock knob to a firm feel. See Fig. 7. Adjust the length of the tripod legs to a comfortable viewing height using the leg locks (22, Fig. 1 or 2).
7. **Attach the red dot viewfinder:** Some telescope viewfinders have a slip-fit type bracket for easy attachment. Just slide the viewfinder into the bracket and tighten the locking screw. Other telescopes have two mounting screws that attach the finder. See Figs. 9a and 9b.
8. **Attach the 90° erect-image prism (refractor models only):** Pull out to remove the plastic dust cover from the eyepiece holder. Slide the tube of the erect-image prism (4, Fig. 1 or 2) into the telescope’s eyepiece-holder (3, Fig. 1 or 2 e) and tighten the thumbscrews (to a firm feel only) to secure the diagonal prism in place.
9. **Insert the eyepiece:** Remove the supplied eyepiece (5, Fig. 1 or 2) from its container and place it in the erect-image prism (*refractor models only*) or directly into the eyepiece holder (3, Fig. 11, *reflector models only*). Tighten the thumbscrews (2 and 4, Fig. 10, *refractor models only*) to a firm feel only. Tighten the thumbscrew (3, Fig. 11, *reflector models only*) to a firm feel only.
10. **Insert batteries:** The telescope’s battery compartment (1, Fig. 12) is located on top of the drive base. Open the battery compartment by lifting the cover and pulling it away from the drive base. See Figure 12 on page 16.
11. Remove the battery holder from the compartment and carefully lift the 9v connector out from the compartment. Take care not to accidentally detach the wires of the battery connector from the base. Whenever you replace the batteries, to safeguard the wires, disconnect the 9v connector from the battery holder before removing the batteries.



Looking at or near the **Sun** will cause **irreversible** damage to your eye. Do not point this telescope at or near the Sun. Do not look through the telescope as it is moving.



Fig. 7: Attach Vixen-style dovetail to mounting arm.



Fig. 8: Balance the optical tube.



Fig. 9a: Slide viewfinder into slip-fit bracket.



Fig. 9b: Unscrew mounting knobs and attach viewfinder. Replace knobs and tighten to a firm feel.

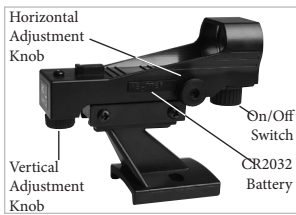

Fig. 9c Red Dot Viewfinder On/Off Switch. Turn the switch to the clockwise to turn on the viewfinder and adjust its intensity. Turn the switch counter-clockwise to turn off.

12. Insert eight AA-size batteries into the battery holder, oriented as shown on the diagram on the battery slots of the battery holder. Connect the 9v connector plug to the battery holder. Carefully replace the battery holder back into the battery compartment. Replace the cover.

**CAUTION:** Use care to install batteries as indicated by the battery compartment. Follow battery manufacturer's precautions. Do not install batteries backwards or mix new and used batteries. Do not mix battery types. If these precautions are not followed, batteries may explode, catch fire, or leak. Improperly installed batteries void your Meade warranty. Always remove the batteries if they are not to be used for a long period of time.

The second option is to use the optional AC power supply. Plug the AC adapter into the power port located on the base/mount assembly. Carefully take the other end and plug it into any 12v outlet.

13. **Connect AudioStar:** Be certain that the power switch on the computer control panel is in the OFF position. Plug the coil cord of the AudioStar Controller into the HBX port. Turn on the power switch; the red LED lights when power is supplied to the panel. See **Fig. 1 or 2 C**.

**NOTE:** The AudioStar handbox does not require batteries; the telescope's batteries supply power to AudioStar.

14. **Remove the dust cover:** Pull out the dust cover (13, Fig. 1 or 2) from the optical tube assembly.

Assembly of the basic telescope is now complete!

## The Red Dot Viewfinder

Because the main telescope has a fairly narrow field of view, locating objects directly in the main telescope can sometimes be difficult. The red dot viewfinder (**Fig. 9**) projects a small red dot that permits you to more easily locate objects. When the red dot viewfinder and optical tube are aligned to each other, both point to the same position in the sky. An object located in the viewfinder is therefore in the eyepiece of the main telescope.

### Aligning the Red Dot Viewfinder:

It is recommended that you perform steps 1 through 4 of this procedure during the daytime and step 5 at night.

1. Loosen the tripod base lock knob (Fig. 17) and the Altitude lock (Fig. 10), so that the telescope can move freely.
2. If you have not already done so, place a low-power (e.g., 26 mm) eyepiece in the erect-image prism of the main telescope and point the telescope at an easy-to-find land object (e.g., the top of a telephone pole or sign). Turn the focuser knob (1, Fig. 1 or 2) to focus the image in the eyepiece. Centre the object precisely.
3. Re-tighten the tripod base lock knob (17 Fig. 1 or 2) and the Altitude lock (10 Fig. 1 or 2) so that the telescope does not move during the procedure.
4. Attached the red dot finder to the telescope. Depending on the model that you have the red dot finder will either slide the red dot finder into the finder holder spot or use the two thumb screws to attach the base to the telescope.
5. For the owners of the refractors or makutov-cassegrain telescopes, take the viewfinder and slide the base of the finder into the finder base and hand tighten the locking screw so that the finder stays in place. (Fig. 9a)
6. For owners of the Newtonian reflectors, remover the two locking screw on the finder base



Looking at or near the **Sun** will cause **irreversible** damage to your eye. Do not point this telescope at or near the Sun. Do not look through the telescope as it is moving.

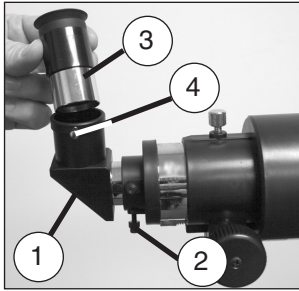

Fig. 10: Attach the diagonal prism (1), tighten prism thumbscrews (2), insert the eyepiece (3), tighten eyepiece thumbscrews (4) (Refractor models).

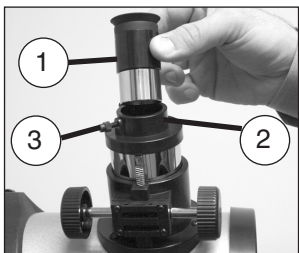

Fig. 11: Insert the eyepiece (1) into the eyepiece holder (2), tighten eyepiece thumbscrew (3) (Reflector models).

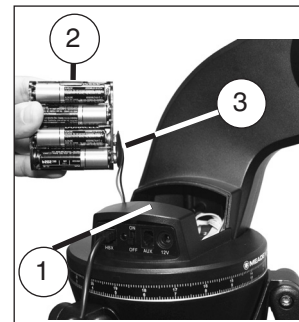

Fig. 12: Insert eight AA-size batteries inside the battery compartment:  
 (1) Battery compartment  
 (2) Battery holder  
 (3) 9v connector



Fig. 13: Connect AudioStar to the HBX port.

(Fig.9b ) place the finder scope onto the base and use the two screws to tighten the finder scope in place.

7. Turn the knob at the front of the finder scope to the right to turn the red dot viewfinder on (by changing the knob's position, you can change the intensity of the red dot. Looking through the viewfinder, turn the viewfinder's two alignment screws (8 Fig. 1 or 2) until the viewfinder's red dot points precisely at the same object as centered in the eyepiece. The red dot viewfinder is now aligned to the main telescope.
8. Check this alignment on a celestial object, such as the Moon or a bright star, and make any necessary refinements.

## Choosing an Eyepiece

A telescope's eyepiece magnifies the light gathered by the optical tube. Each eyepiece has a focal length, expressed in millimeters, or "mm." The smaller the focal length, the higher the magnification. For example, an eyepiece with a focal length of 9mm has a higher magnification than an eyepiece with a focal length of 26mm.

Your telescope comes supplied with a low-powered 26mm eyepiece which gives a wide, comfortable field of view with high image resolution. Always begin your observations with this eyepiece.

Low power eyepieces offer a wide field of view, bright, high-contrast images, and eye relief during long observing sessions. After an object is located and centered in the eyepiece, try switching to a higher power eyepiece to enlarge the image.

**NOTE:** Viewing conditions vary from night-to-night and from site-to-site. Turbulence in the air, even on an apparently clear night, can distort images. If an image appears fuzzy and ill-defined, return to a lower power eyepiece for a more well-resolved image.

The power, or magnification of a telescope is determined by the focal length of the telescope and the focal length of the eyepiece being used. To calculate eyepiece power, divide the telescope's focal length by the eyepiece's focal length. For example, you may wish to use a 26 mm eyepiece with the StarNavigator102. Look up the focal length of the StarNavigator102 under SPECIFICATIONS.

Telescope focal length divided by Eyepiece focal length = Eyepiece power

660 divided by 26 = 25. The eyepiece power, or magnification is therefore 25X (approximately).

★ STARNAVIGATOR TIPS ★

Join an Astronomy Club  
Attend a Star Party

A fun way to learn more about astronomy is to join an astronomy club. Check your local newspaper, school, library, or telescope dealer to find out if there's a club in your area.

At club meetings, you will meet other astronomy enthusiasts with whom you will be able to share your discoveries. Clubs are an excellent way to learn more about observing the sky, to find out where the best observing sites are, and to compare notes about telescopes, eyepieces, filters, tripods, and so forth.

Often, club members are excellent astrophotographers. Not only will you be able to see examples of their art, but you may even be able to pick up some "tricks of the trade" to try out on your telescope.

Many groups also hold regularly scheduled Star Parties at which you can check out and observe with many different telescopes and other pieces of astronomical equipment. Magazines such as *Sky & Telescope* and *Astronomy* print schedules for many popular Star Parties around the United States and Canada.

Looking at or near the Sun will cause irreversible damage to your eye. Do not point this telescope at or near the Sun. Do not look through the telescope as it is moving.





Fig. 14: 26mm and 9.7mm eyepieces.

## OBSERVING

### Observing by Moving the Telescope Manually

If you wish to observe a distant land object, such as a mountain top or a bird, you can observe by merely pointing the telescope and looking through the eyepiece.

1. Loosen the telescope's tripod base lock knob (17, Fig. 1 or 2) and Altitude lock (10F, Fig. 1 or 2 b), so that the telescope can move freely.
2. Point your telescope at distant street signs, mountains, trees, and other structures. Use your red dot viewfinder to help site-in on an object.
3. Center the object using the red dot viewfinder and then in the telescope eyepiece. When the object is centered in your eyepiece, re-tighten the base and Altitude locks.
4. Practice focusing objects with the focus knob (1, Fig. 1 or 2).
5. Once you get a feel for how your telescope moves and focuses, try to view something more challenging, like a bird or a distant moving train.

You can also observe stars and objects in the night sky using this method, but note that objects begin to slowly drift across the eyepiece field. This motion is caused by the rotation of the Earth. As you become familiar with the AudioStar handbox operation, you can counteract the drift using the automatic tracking feature in the AudioStar Setup menu (see **TO TRACK AN OBJECT AUTOMATICALLY**, page 19), or by using AudioStar's GO TO capabilities (see **GO TO SATURN**, page 22).



**NEVER**  
point the  
telescope  
directly

**at or near the Sun at any time! Observing the Sun, even for the smallest fraction of a second, will result in instant and irreversible eye damage, as well as physical damage to the telescope itself.**

### Terrestrial Observing

StarNavigator NG refracting telescopes are excellent high-resolution, terrestrial (land) telescopes (reflecting telescopes are designed primarily for astronomical observations). Viewing terrestrial objects requires looking along the Earth's surface through heat waves. These heat waves often cause degradation of image quality. Lower power eyepieces, such as a 26mm eyepiece, magnify these heat waves less than higher power eyepieces. Therefore, lower power eyepieces provide a steadier, higher quality image. If the image is fuzzy or ill-defined, reduce to a lower power eyepiece, where the heat waves do not have such an effect on image quality. Observing in early morning hours, before the ground has built up internal heat, produces better viewing conditions than during late afternoon hours.

### Observing Using AudioStar's Arrow Keys

You may observe land and astronomical objects using AudioStar's Arrow keys to move the telescope.

1. Tighten the Altitude lock knob (10F, Fig. 1 or 2 b) and tripod base lock knob (17, Fig. 1 or 2).
2. Make sure the telescope power switch is in the OFF position. Plug AudioStar into the HBX port of the Control Panel.
3. Flip the telescope power switch to the

STARNAVIGATOR TIPS

### Too Much Power?

Can you ever have too much power? If you're referring to eyepiece power (magnification), yes, you can! The most common beginner's mistake is to "overpower" a telescope by using too high of a magnification, which the telescope's aperture and atmospheric conditions cannot reasonably support. Keep in mind that a smaller, but bright and well-resolved image is far superior to one that is larger, but dim and poorly resolved (see below). Powers above 200X should be employed only under the steadiest atmospheric conditions.

AudioStar can calculate the best eyepiece for you to use. Try out the "Eyepiece Calc" feature in the Utilities menu.

Most observers should have three or four additional eyepieces to achieve the full range of reasonable magnifications possible with the StarNavigator telescopes. See "OPTIONAL ACCESSORIES," page 35.

**Fig. 15 & 15:** Jupiter; example of too much magnification.



Looking at or near the **Sun** will cause **irreversible** damage to your eye. Do not point this telescope at or near the Sun. Do not look through the telescope as it is moving.

**Important Note for Reflecting Telescope Owners:** When you look through your telescope's eyepiece, the image might look strange at first.

If you have a **reflecting telescope**, objects will appear upside down and reversed left-for-right. This will not make a difference when observing astronomical objects, and in fact, all Reflecting telescopes present inverted images. There is no means of correcting the image. This is normal.

ON position.

4. AudioStar is activated and a copyright message displays briefly, followed by a short beep. Then AudioStar takes a few moments to start up the system.
5. The Arrow keys are now activated. Press the Arrow keys (**5, Fig. 3**) to slew (move) the telescope up, down, right, or left.
6. Press a NUMBER key (**6, Fig. 3**) to change the telescope's slew speed. Each time you press a number from 1 through 9, the speed will change. See **SLEW SPEEDS**, page 18, for more information.
7. Use the red dot viewfinder (**7, Fig. 1 or 2**) to locate an object and practice using the AudioStar's Arrow keys to center the object in the telescope eyepiece's field of view.
8. Use the telescope's focus knob (**1, Fig. 1 or 2**) to bring the object into focus.

## Slew Speeds

AudioStar has nine slew speeds that are directly proportional to the sidereal rate (see **TO TRACK AN OBJECT AUTOMATICALLY** below for a definition of "sidereal rate") and have been calculated to accomplish specific functions. Pressing a number key changes the slew speed, which is shown for about two seconds on AudioStar's display.

The nine available speeds are:

- Number 1 = 1x = 1 x sidereal (0.25 arc-min/sec or 0.004°/sec)
- Number 2 = 2x = 2 x sidereal (0.5 arc-min/sec or 0.008°/sec)
- Number 3 = 8x = 8 x sidereal (2 arc-min/sec or 0.033°/sec)
- Number 4 = 16x = 16 x sidereal (4 arc-min/sec or 0.067°/sec)
- Number 5 = 64x = 64 x sidereal (16 arc-min/sec or 0.27°/sec)
- Number 6 = 0.5° = 120 x sidereal (30 arc-min/sec or 0.5°/sec)
- Number 7 = 1°/s = 240 x sidereal (60 arc-min/sec or 1°/sec)
- Number 8 = 1.5°/s = 360 x sidereal (90 arc-min/sec or 1.5°/sec)
- Number 9 = Max = (Maximum speed possible, dependent on battery power)

**Speeds 1, 2, or 3:** Best used for fine centering of an object in the field of view of a higher power eyepiece, such as a 12mm or a 9mm eyepiece.

**Speeds 4, 5, or 6:** Enables centering an object in the field of a low-to-moderate power eyepiece, such as a standard 26mm eyepiece.

**Speeds 7 or 8:** Best used for rough centering of an object in the eyepiece.

**Speed 9:** Moves the telescope quickly from one point in the sky to another.

## Playing the Audio

The StarNavigator telescope is equipped with Astronomer Inside technology. This revolutionary technology provides object descriptions of night sky objects while you are viewing them. Object descriptions for the Moon, planets, stars, clusters, nebulae and galaxies are presented by Astronomer Inside. Information such as temperature, size, distance and mythology are presented in a fun and entertaining way.

To activate Astronomer Inside technology a night sky object needs to be selected. To select an object, go to the Object menu. See page 25 on navigating the Objects menu.

Once an object is selected on the AudioStar, an audio presentation for that object will begin to play. While the audio is playing, the volume can be adjusted by pressing the 7 (volume down) or 9 (volume up) keys. To skip the current audio file and play the next, press the ? key. If there are no other audio files for that object, the audio will stop playing. If multiple audio files are available, keep pressing the "?" key to skip the audio until it stops.



Looking at or near the **Sun** will cause **irreversible** damage to your eye. Do not point this telescope at or near the Sun. Do not look through the telescope as it is moving.

**NOTE:**

*Do not look through the telescope's eyepiece or viewfinder while it is rapidly moving. Children should always have adult supervision while observing.*

**TIP:**

*When a message is scrolling across the display, press and hold the Up scrolling key to increase the scrolling speed or press and hold the Down scrolling key to decrease the scrolling speed.*

**Observe the Moon**

Point your telescope at the Moon (note that the Moon is not visible every night) and practice using the Arrow keys and the slew speeds to view different features. The Moon contains many interesting features, including craters, mountain ranges, and fault lines. The best time to view the Moon is during its crescent or half phase. Sunlight strikes the Moon at an angle during these periods and adds a depth to the view. No shadows are seen during a full Moon, causing the overly bright surface to appear flat and rather uninteresting.

Consider the use of a neutral density Moon filter when observing the Moon. Not only does it cut down the Moon's bright glare, but it also enhances contrast, providing a more dramatic image.

**Astronomical Observing**

Used as an astronomical instrument, your telescope has many optical and electromechanical capabilities. It is in astronomical applications where the high level of optical performance is readily visible.

**To Track an Object Automatically**

As the Earth rotates beneath the night sky, the stars appear to move from East to West. The speed at which the stars move is called the sidereal rate. You can setup your telescope to move at the sidereal rate so that it automatically "tracks" the stars and other objects in the night sky. In other words, if the telescope is not tracking an astronomical object, the object will drift out of the eyepiece field of view. The tracking function automatically keeps an object more or less centered in the telescope's eyepiece.

To track objects, you must first set the telescope in the home position, then initialize AudioStar, and finally select "Targets: Astronomical" from the AudioStar Setup menu. You must also learn how the AudioStar keypad operates in order to move through the AudioStar menus.

**The "Alt/Az" Home Position**

1. Loosen the telescope's Altitude lock (see **Fig. 17**).
2. Level the optical tube with the horizon: Line up 0° on the Altitude setting circle (**Fig. 16**) with the triangular pointer.
3. Tighten the Altitude lock (**Fig. 17**) to a firm feel only.
4. Loosen the tripod base lock knob (**17, Fig. 1 or 2**).
5. Move the tube until the tube points North. Use a compass or line it up with Polaris, the North star.
6. Tighten the tripod base lock knob (**17, Fig. 1 or 2**) to a firm feel. Press ENTER on the AudioStar handbox.

**Moving Through AudioStar's Menus**

AudioStar's menus are organized for quick and easy navigation.

- Press ENTER to go deeper into AudioStar's menu levels.
- Press MODE to move back toward the top menu level.
- Press the Scroll keys to move through the options available for each level.
- Press the Arrow keys to enter characters and digits.
- The Arrow keys are also used to move the telescope.

**Initializing AudioStar**

This section describes how to initialize AudioStar. Perform this procedure the first time you use AudioStar or after performing a RESET (see **RESET**, page 30).

1. **Tighten Locks:** Tighten the Altitude lock (**10F, Fig. 1 or 2 b**) and tripod base lock knob (**17, Fig. 1 or 2**).
2. **Plug in AudioStar:** Make sure the telescope power switch is in the OFF position. Plug AudioStar into the HBX port of the Control Panel.
3. **Turn on AudioStar:** Flip the telescope power switch to the ON position.
4. **Set Your Location or Zip Code:** The Location screen displays. This screen asks you if you wish to choose either the zip code of your observing location or the location (*i.e.*, entering



Looking at or near the **Sun** will cause **irreversible** damage to your eye. Do not point this telescope at or near the Sun. Do not look through the telescope as it is moving.

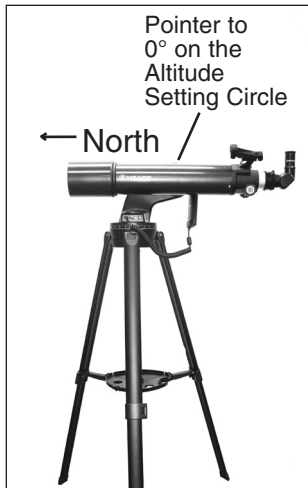

Fig. 16: Alt/Az Home Position.



Fig. 17: Altitude lock and setting circle.

**DEFINITION:**

**Initialization** is a procedure that ensures that AudioStar operates correctly. When you first use AudioStar, it doesn't yet know where the observation location site is.

During the procedure, you will enter the observation location. AudioStar uses this information to precisely calculate the location of celestial objects (such as stars and planets) and to move your telescope correctly for various operations.

the city and state or country of your observing location). Press Up to select the zip code option or down to enter the city and state.

**Note:** The location settings (country/state/province and city, or zip code) are only asked for the first time you turn on the control panel. If you wish to change this setting later on, use the Site menu. See **SITE**, pages 30, for more information.

- a. If you chose the zip code option, the leftmost "0" is highlighted. Use the Number keys to enter the digits. As you enter a digit, the next digit to the right will be highlighted. Enter the next digit. Repeat this process until all 5 digits of your zip code are entered. Press ENTER.
  - b. If you chose the location option, the next screen asks for the country or state/province (listed alphabetically) of the observing site.
5. Use the Scroll keys to scroll through the list of countries, states, and provinces. Press ENTER when the correct location displays.
  6. The next screen asks for the city (listed alphabetically) closest to the observing site. Use the Scroll keys to scroll through the list of cities. Press ENTER when the correct city appears on screen.
  7. **Daylight Savings Time:** The next screen requests the status of Daylight Savings Time. Press one of the Scroll keys to toggle between the YES/NO settings. When the desired setting displays, press ENTER.

**NOTE:** When multiple choices are available within a menu option, the current option is usually displayed first and highlighted by a right pointing Arrow (>).

8. AudioStar then requests the telescope model number. Use the Scroll keys to cycle through the database of models. Press ENTER when your model number displays.
9. **System initialization is complete.** The Easy Alignment feature begins automatically after the control panel is initialized.

**Observe a Star using the Automatic Tracking Feature**

In this example, the AudioStar Arrow keys are used to find a star, and then AudioStar's tracking capability automatically keeps the star centered in your telescope's eyepiece.

1. **Set in Home Position:** Level the optical tube and point it True North. Make sure that the Altitude Lock (10F, Fig. 1 or 2 b) and tripod base lock knob (17, Fig. 1 or 2) are secured as described previously.
2. **Plug in AudioStar:** Make sure the telescope power switch is in the OFF position. Plug AudioStar into the HBX port of the Control Panel.
3. **Turn on AudioStar:** Flip the telescope power switch to the ON position.
4. **Select Daylight Savings:** Set Daylight Savings, if prompted.
5. **Select Setup: Align Option:** Press MODE (3, Fig. 2). "Setup: Align" displays.
6. **Select Setup: Targets Option:** Press the Scroll Down key repeatedly until "Setup: Targets" displays. Press ENTER (2, Fig. 3).
7. **Select Targets: Astronomical Option:** "Targets: Terrestrial" displays. Press either of the Scroll keys once (7, Fig. 3). "Targets: Astronomical" now displays.
8. **Locate a Bright Star:** Use the Arrow keys (5, Fig. 3) to locate a bright star in the night sky. Use the viewfinder (7, Fig. 1 or 2) to help line up on the star. You may choose any unobstructed, bright star for the purposes of this example. Use AudioStar's Arrow keys to center the star in the eyepiece.
9. **To Start Tracking:** Once the star is centered, press ENTER to select "Astronomical." The telescope's tracking motors then engage. It may take the tracking motors several seconds to begin tracking. When they do, it may be necessary to once again center the star in the eyepiece. The tracking motors will then keep the star you have chosen in the center of the eyepiece.
10. If you wish to track another star, use the Arrow keys to slew the telescope to the star. Center the star. The tracking motors will then keep that star in the center of the eyepiece.



Looking at or near the **Sun** will cause **irreversible** damage to your eye. Do not point this telescope at or near the Sun. Do not look through the telescope as it is moving.

**IMPORTANT NOTE:**

AudioStar requests the Zip Code or Country/ State, City, and Telescope Model information only the first time AudioStar is activated. If you wish to change this information, use the "Site" and "Telescope Model" options in the Setup menu. See pages 28 for more information.

**IMPORTANT NOTE:**

While performing the automatic tracking procedure, only use the Arrow keys to move the telescope. Once the telescope has been set in the Alt/Az home position, do not loosen the telescope locks (10F, Fig. 1 or 2 b), or move the base manually, or alignment will be lost.



Fig. 18: One of the most beautiful celestial sights, Saturn.

**11. To Stop Tracking:** Press ENTER. "Setup: Targets" displays. Press ENTER. "Targets: Astronomical" now displays. Press either of the Scroll keys once. "Targets: Terrestrial" displays. Press ENTER. Tracking is now turned off.

**Easy (Two-Star) Align**

The fastest and easiest way to locate objects with AudioStar's GO TO capabilities is to use Easy Align.

AudioStar automatically picks two stars from its database for the Easy Align procedure. During this procedure, AudioStar slews the telescope to a first alignment star. The user is asked to verify that the telescope is pointed at the chosen star and then prompted to center the star in the eyepiece. The process is repeated with a second star to complete the alignment. See the StarNavigator Tips on page 22 for some useful information.

**NOTE:** Before aligning the telescope, first verify that **INITIALIZING AudioStar**, page 19, has been performed. See **MOVING THROUGH AUDIOSTAR'S MENUS**, page 19, if you wish to learn how to operate AudioStar's keys.

**How to Easy Align Your Telescope**

If you have performed Initializing AudioStar as shown on page 19, continue to step 2. Otherwise, before proceeding, please perform the steps shown on page 19, Initializing AudioStar.

**NOTE:** For the Easy Align procedure to function properly, AudioStar must have the correct time, date and location of the observing site. If you have changed locations since your telescope was last used, or would like to change this information, see the Setup Menu on page 28 for more information.

1. Option Screen - AudioStar displays "Press 0 to Align or MODE from the Menu." Press "0" to begin the Easy Align procedure.
2. North Method -"North Method: 1=True 2=Compass" displays. Press the 1 key if you will be placing the telescope in the True North Home Position. Press the 2 key if you will be placing the telescope in the Magnetic North Home Position. See page 19 for more information on setting the telescope into the Home Position.
3. Set Alt/Az Home Position - Audiostar then prompts you to set the telescope in the Alt/Az Alignment home position. See SET ALT/AZ HOME POSITION, page 19 .
4. Star Alignment - Audiostar then chooses two stars to align upon. When the telescope slews to the first star for alignment, it may not appear in the field of view in the eyepiece. The alignment star should be easily recognized and be the brightest star in the area of the sky where the telescope is pointing. Use the Arrow keys to move the telescope until the star is visible and centered in the eyepiece. Press ENTER. Repeat procedure for the second alignment star.

When the procedure is performed correctly, "Alignment Successful" displays. If Audiostar does not display this message, perform this procedure again.

**NOTE:** Audiostar locates alignment stars based on the date, time, and location entered. The alignment stars may change from night to night. All that is required is for the observer to center the selected stars in the eyepiece when prompted.

**NOTE:** The GO TO key also allows you to perform a "spiral search." A spiral search is useful when the telescope slews to an object, but that object is not visible in the eyepiece after the telescope finishes its search. (This sometimes occurs during an alignment procedure.) Press GO TO when the slew is finished and the telescope starts slewing in a spiral pattern at a very slow speed around the search area. Look through the eyepiece and when the object does become visible, press MODE to stop the spiral search. Then use the Arrow keys to center the object.

Two other methods of alignment are available to the observer: Two-Star and One-Star. These methods are included in case the observer prefers to pick out his or her own alignment stars.

 Looking at or near the **Sun** will cause **irreversible** damage to your eye. Do not point this telescope at or near the Sun. Do not look through the telescope as it is moving.

## Two-Star Alt/Az Alignment

Two-Star Alignment requires some knowledge of the night sky. Two-Star Alignment is identical to Easy: Align (see **EASY (TWO-STAR) ALIGN**, Pg. 21), except AudioStar displays a database of bright stars and *two* stars are chosen *by the user* from this database for alignment. It is recommended that you choose stars with which the user is familiar from this database when first trying out this method or the One-Star Alignment method.

## One-Star Alt/Az Alignment

One-Star Alignment also requires some knowledge of the night sky. One-Star Alignment is identical to Easy: Align (see **EASY (TWO-STAR) ALIGN**, Pg. 21), except AudioStar displays a database of bright stars and *one* star is chosen *by the user* from this database for alignment.

**IMPORTANT NOTE:** *The accuracy of One-Star Alt/Az Alignment, unlike the Two-Star Alignment procedures, depends on how well the user levels the telescope and how close to North the telescope is pointed when setting the Home Position (Fig. 16). Because the Two-Star Alignment methods use two stars to align upon, they are more precise than One-Star Alignment.*

## Go To Saturn

After performing the Easy Align procedure, the motor drive begins operating and the telescope is aligned for a night of viewing. Objects in the eyepiece should maintain their position even though the Earth is rotating beneath the stars.

**IMPORTANT NOTE:** *Once aligned, only use GO TO or the Arrow keys to move the telescope. Do not loosen the telescope locks (10F, Fig. 1b and 17, Fig. 1), or move the base manually, or alignment will be lost.*

This exercise shows how to select a celestial object (Saturn) for viewing from AudioStar's database.

**NOTE:** *Saturn is not visible all the time and you may need to choose another object from AudioStar's Object database; however, the procedure, as described below, remains the same; just choose a different object in step #3.*

1. After the telescope is aligned, "Select Item: Object" displays. Press ENTER.
2. "Object: Solar System" displays. Press ENTER.
3. "Solar System: Mercury" displays. Keep pressing the Scroll Down key until "Solar System: Saturn" displays.
4. Press ENTER. "Calculating" displays. Then "Saturn" and a set of coordinates displays. Note that Saturn's (and other planets') coordinates change throughout the year.
5. Press GO TO. "Saturn: Slewing..." displays and the telescope slews until it finds Saturn. You may need to use the Arrow keys to center Saturn precisely in the eyepiece. AudioStar then automatically moves the telescope so that it "tracks" Saturn (or whatever other object you may have chosen); *i.e.*, Saturn remains centered in the eyepiece.

## Take a Guided Tour

This example demonstrates using "Tonight's Best" Guided Tour.

1. After observing Saturn, press MODE twice so that "Select Item: Object" displays again.

**STARNAVIGATOR TIPS**

### Which One's the Alignment Star?

If AudioStar has chosen an alignment star with which you are unfamiliar, how can you be sure if the star in your eyepiece is really the alignment star?

The rule of thumb is that an alignment star is usually the brightest star in that area of the sky. When you view an alignment star in an eyepiece, it stands out dramatically from the rest of the stars in that portion of the sky.

If you have an obstruction, such as a tree or a building blocking your view of the alignment star, or if you have any doubts at all about the star that has been chosen, no problem. Just press the Scroll Down key and AudioStar will find another star to align upon.

 Looking at or near the **Sun** will cause **irreversible** damage to your eye. Do not point this telescope at or near the Sun. Do not look through the telescope as it is moving.

2. Press the Scroll Down key twice. “Select Item: Guided Tour” displays.
3. Press ENTER. “Guided Tour: Tonight’s Best” displays. Press ENTER.
 

**NOTE:** If you wish to try out other Guided Tours, press the Scroll Down key to scroll through other tour choices. When the tour you wish to select displays, press ENTER.
4. “Tonight’s Best: Searching...” displays. After calculating, “Tonight’s Best: Jupiter” displays.
 

**NOTE:** Different objects may be displayed on a tour list on any given night.

Press ENTER to display information about the object. Press GO TO to move the telescope to the object.
5. Press MODE to return to the Tour list. Press the Scroll keys to scroll through the list. Press ENTER when you find the next object you wish to observe.
6. Press and hold down MODE for two seconds to exit the Guided Tour menu.

## BASIC AUDIOSTAR OPERATION

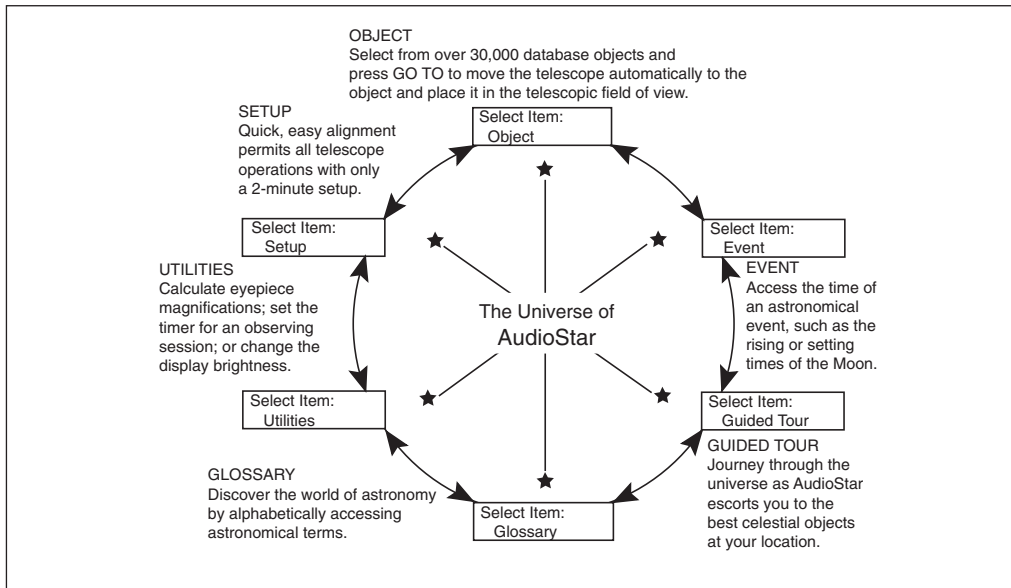

Fig. 19: The AudioStar Universe: The six primary categories listed in the Select Item menu of AudioStar.

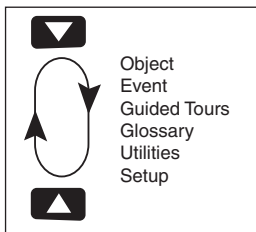

Fig. 20: Menus set in a loop.

It is important to understand that menu selections are set in a loop (**Fig. 20**). This means that pressing the Scroll Down key (**7, Fig. 3**) cycles down through all the available options within a given category, then returns to the first option. The Scroll Up key cycles up through the options in the opposite order. Note that this capability is a quick way to get to an option that is near the bottom of the list. The following example demonstrates this capability.

**Example:**

To navigate to the “Select Item: Setup” menu option when the “Select Item: Object” menu is displayed:

1. Press the Scroll Down key four times or the Scroll Up key once.

AudioStar displays two lines of information. The top line shows the current menu level. The second line displays an option which may be selected within that menu level. Some options are choices that select the next menu level down. The Scroll keys move up and down within the list of available options, showing one option at a time.

When the desired option is displayed on the second line, press the ENTER key to choose that option and move down one menu level.

Press the MODE key to leave a level (e.g., the wrong menu option is chosen).

**IMPORTANT NOTE:** No matter how many levels into AudioStar are traveled,

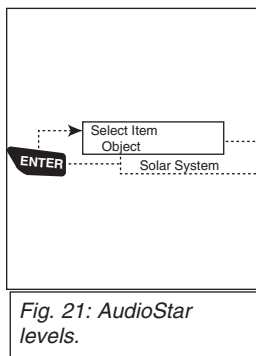

Fig. 21: AudioStar levels.

 Looking at or near the **Sun** will cause **irreversible** damage to your eye. Do not point this telescope at or near the Sun. Do not look through the telescope as it is moving.

**TIP:** When multiple choices are available within a menu option, the option that is currently selected is usually displayed first and highlighted by a right pointing arrow (>).

each press of the **MODE** key moves up a level, until the top level, “Select Item,” is reached. Once in the Select Item level, press **MODE** to return to the topmost level, “Select Item: Object.”

### AudioStar Navigation Exercise

To demonstrate how the AudioStar menu structure works, the following exercise calculates Sunset time so an evening observing session can be planned.

**NOTE:** To perform an accurate calculation, AudioStar must be properly initialized with the current date, time, and location of the observing site. To enter the current date, time, and location information of your observing site, see **INITIALIZING AudioStar**, page 19, before proceeding with this exercise.

#### To Calculate Sunset time:

1. Press the **MODE** key several times, until “Select Item: Object” is displayed.
2. Press the Scroll Down key once to display the “Event” option in the “Select Item” menu.
3. Press the **ENTER** key to choose the “Event” option and move down a level. “Event: Sunrise” is displayed.
4. Press the Scroll Down key once to display the “Sunset” option in the Event menu.
5. Press the **ENTER** key to choose the “Sunset” option and move down another level.
6. AudioStar calculates the Sunset time based on the current date, time, and location. AudioStar then displays the results of the calculation.
7. Press **MODE** once to start moving back up through the AudioStar levels. The first level up is the Event menu.
8. Press **MODE** again to move up another level. This is the top level, “Select Item.”
9. Press **MODE** again to return to the starting point of “Select Item: Object.”

### Entering data into AudioStar

- To enter numbers and text:a) Use the Number keys to enter digits, or
- b) Use the Arrow keys to scroll through numbers 0 - 9 and the alphabet. The Down Arrow key begins with the letter “A;” the Up Arrow key begins with digit “9.”
- To move the cursor across the display:
- Use the Right or Left Arrow key (**5, Fig. 3**) to move the cursor from one number to the next in the display
- Press **ENTER** when the desired information has been entered.

### Navigating AudioStar

AudioStar’s menus are organized for quick and easy navigation:

- Press **ENTER** to go deeper into AudioStar’s menu levels.
- Press **MODE (3, Fig. 3)** to move back toward the top menu level.
- Press the Scroll keys to move up and down through the options or lists
- Press the Arrow keys to move the cursor across the display.
- Press the Help (?) key to access the help function.

### Adjusting the Speed of a Scrolling Message

- Press and hold the Scroll Up key to increase the scrolling speed when a message is scrolling across the display.
- Press and hold the Scroll Down key to decrease the scrolling speed when a message is scrolling across the display.



Looking at or near the **Sun** will cause **irreversible** damage to your eye. Do not point this telescope at or near the Sun. Do not look through the telescope as it is moving.



# MENUS AND MENU OPTIONS

## Object Menu

Almost all observing with AudioStar is performed using the Object menu category. (**NOTE: Exceptions include Guided Tour and Landmark Survey.**) See **GO TO SATURN**, page 22, for an example of observing using the Object menu. Also see **TAKE A GUIDED TOUR**, page 22.

Many AudioStar menu categories contain databases. An AudioStar *database* is a list of viewable objects, such as stars, planets, comets, nebulae and so forth. When one of these objects is selected from a database, AudioStar moves your telescope (if properly aligned) and points it at the selected object.

The Object Menu options include:

**Solar System** is a database of the eight planets (Earth is not included) in order out from the Sun, followed by the Moon, asteroids, and comets.

**Constellation** is a database of all 88 Northern and Southern Hemisphere constellations. When this menu option is chosen and a constellation name appears on the first line of the screen, press GO TO once to change the second line to the name of the brightest star in the constellation. Press GO TO a second time to slew the telescope to that star. Use the Scroll keys to cycle through the list of stars in the constellation, from brightest to dimmest.

**Deep Sky** is a database of objects outside our Solar System such as nebulae, star clusters, galaxies, and quasars.

**Star** is a database of stars listed in different categories such as named, double, variable, or nearby.

**Satellite** is a database of Earth-orbiting objects such as the International Space Station, the Hubble Space Telescope, Global Positioning System (GPS) satellites, and geosynchronous orbit satellites.

**User Objects** allows the user to define and store in memory deep-sky objects of specific interest that are not currently in the AudioStar database. See **APPENDIX B** for more information.

**Landmarks** stores the location of terrestrial points of interest in the permanent AudioStar database.

**IMPORTANT NOTE:** *To use the Landmark function, the telescope must be located and aligned exactly as when the landmark was added to the database.*

- **Select:** To select a Landmark already in the database (see **ADD** below), choose the “Select” option and scroll through the list. Press ENTER to select a Landmark, then press GO TO and the telescope slews to the object.
- **Add:** To add a Landmark, choose the “Add” option. Enter a name for the Landmark. Locate and center the Landmark in the eyepiece, then press ENTER.

**Identify** is an exciting feature for an observer who wants to scan the night sky and start exploring. After the telescope has been properly aligned, use the AudioStar Arrow keys to move about in the sky. Then follow this procedure:

**IMPORTANT NOTE:** *Only use the Arrow keys to move the telescope during the Identify procedure. Do not loosen the telescope locks or move the base or alignment is lost.*

1. When a desired object is visible in the eyepiece, keep pressing MODE until the “Select Item: Object” menu is displayed. Press ENTER to select this menu.
2. Scroll through the Object menu options until the “Object: Identify” screen appears.
3. Press ENTER. AudioStar searches the database for the identity of the object being observed.
4. If the telescope is not directly on an AudioStar database object, the nearest database object is located and displayed on the screen. Press GO TO and the telescope slews to that object.

## Event Menu

The Event menu provides access to dates and times of astronomical events. The Event



Looking at or near the **Sun** will cause **irreversible** damage to your eye. Do not point this telescope at or near the Sun. Do not look through the telescope as it is moving.

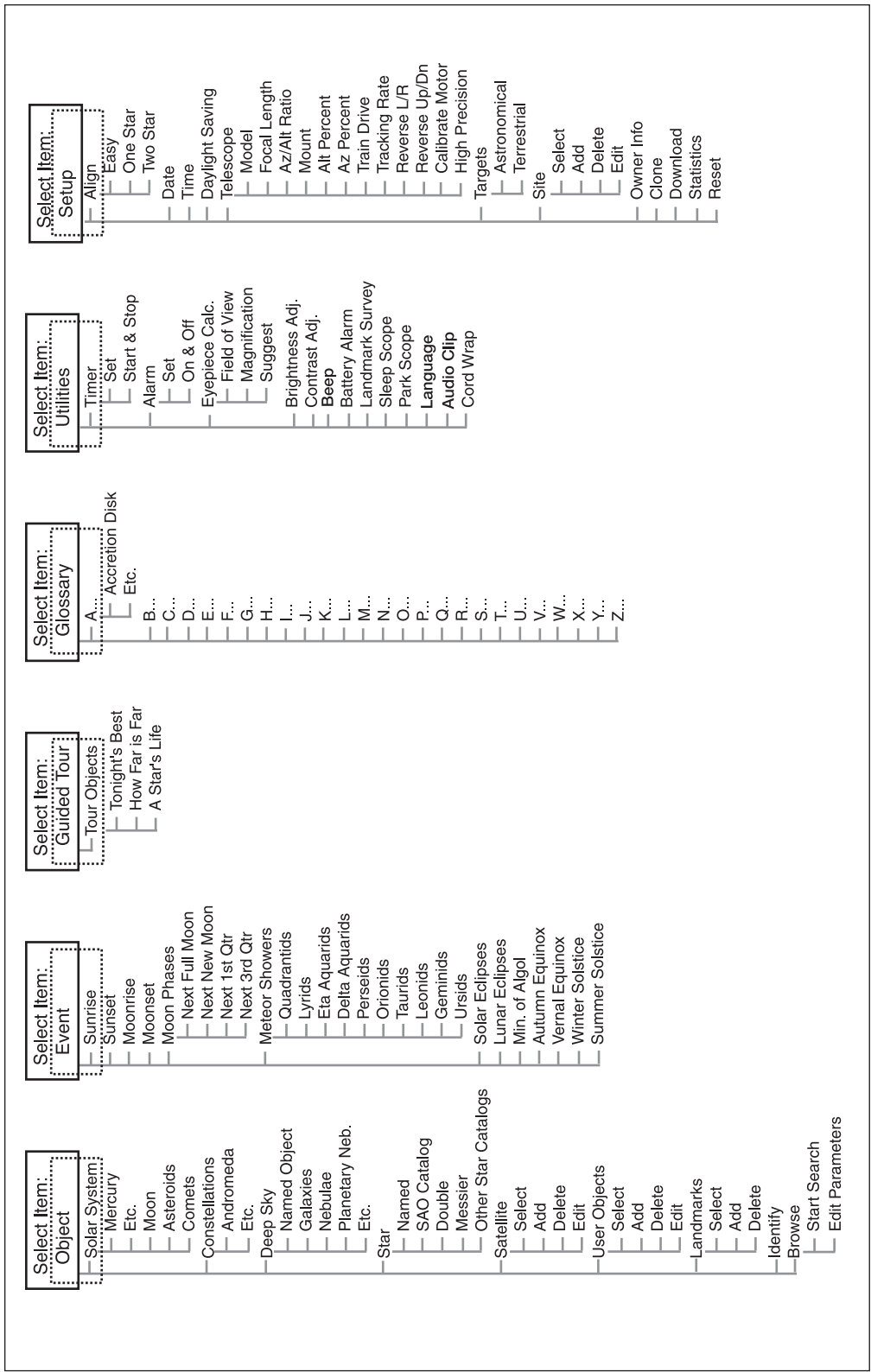

Fig. 22: The Complete AudioStar Menu Structure.

 Looking at or near the **Sun** will cause **irreversible** damage to your eye. Do not point this telescope at or near the Sun. Do not look through the telescope as it is moving.

database includes:

**Sunrise** and **Sunset** calculates the time that the Sun rises or sets on the current date. Find rise and set times for other dates by entering a new date into the “Setup: Date” menu. See **DATE**, page 29.

**Moonrise** and **Moonset** calculates the time that the Moon rises or sets on the current date. Find rise and set times for other dates by entering a new date into the “Setup: Date” menu. See **DATE**, page 29.

**Moon Phases** displays the date and time of the next Full, New, 1st Quarter, and 3rd Quarter Moon.

**Meteor Showers** provides information on upcoming meteor showers, such as the Perseids, the Leonids, *etc.* Also lists the dates of the showers and when they reach maximum.

**NOTE:** *Meteors are fast moving objects that cover large areas of the sky and are usually best observed with the naked eye.*

**Solar Eclipse** lists upcoming Solar Eclipses, including the date and type (total, annular, or partial) of eclipse, and the location and time of the first and last contacts of the Moon’s shadow. Use the Scroll Up and Down keys to display the available data. Remember, never use a telescope to look at the Sun! See **WARNING!** to the left.

**Lunar Eclipse** lists upcoming Lunar Eclipses, including the date and type (total, partial, penumbral) of eclipse. Use the Scroll Up and Down keys to display the available data.

**Autumn** and **Vernal Equinox** calculates the time and date of the fall or spring equinox of the current year.

**Winter** and **Summer Solstice** calculates the time and date of the winter or summer solstice of the current year.

## Glossary Menu

The Glossary menu provides an alphabetical listing of definitions and descriptions for common astronomical terms and AudioStar functions. Access directly through the Glossary menu or through hypertext words embedded in AudioStar. A *hypertext word* is any word in **[brackets]**, usually found when using the AudioStar Help function or when reading a scrolling message such as a description of a planet or star. Press ENTER whenever a hypertext word is on screen and AudioStar goes to the glossary entry for that word.

To access directly from the Glossary menu, use the Scroll keys to scroll through the alphabet. Press ENTER on the desired letter. Scroll to the desired entry and then press ENTER to read the description.

## Utilities Menu

The Utilities menu provides access to several extra features within AudioStar, including a countdown timer and an alarm. The Utilities functions include:

**Timer** selects a countdown timer. This feature is useful for functions such as astrophotography and tracking satellites. See **OBSERVING SATELLITES**, page 47. To use the Timer, press ENTER, then choose “Set” or “Start/Stop.”

- **Set:** Enter the time to be counted down, in hours, minutes, and seconds, then press ENTER.
- **Start/Stop:** Activates the timer set previously. Use the Scroll keys to toggle between ON and OFF. When ON is displayed, press ENTER to activate the timer. When the timer runs out, four beeps sound and the timer is deactivated.
- **Alarm** selects a time for an alarm signal as a reminder. To use the Alarm, press ENTER, then choose “Set” or “Start/Stop.”
- **Set:** Enter the time of day for the alarm to sound, in hours, minutes, and seconds, then press ENTER.
- **Start/Stop:** Activates the alarm set previously. Use the Scroll keys to toggle between ON and OFF. When ON is displayed, press ENTER to activate the alarm. When the alarm time arrives, AudioStar beeps. Press ENTER to deactivate the alarm.
- **Eyepiece Calc** calculates information about an eyepiece for the specific telescope to



### WARNING!

**Never use a Meade StarNavigator Telescope to look at the Sun! Looking at or near the Sun will cause instant and irreversible damage to your eye. Eye damage is often painless, so there is no warning to the observer that damage has occurred until it is too late. Do not point the telescope or its viewfinder at or near the Sun. Do not look through the telescope or its viewfinder as it is moving. Children should always have adult supervision while observing.**



Looking at or near the **Sun** will cause **irreversible** damage to your eye. Do not point this telescope at or near the Sun. Do not look through the telescope as it is moving.

which AudioStar is connected.

- **Field of View:** Scroll through a list of available eyepieces. When an eyepiece is selected, the field of view is calculated.
- **Magnification:** Scroll through a list of available eyepieces. When an eyepiece is selected, the magnification is calculated.
- **Suggest:** AudioStar calculates and suggests the best eyepiece for viewing, based on the telescope and the object being viewed.

**Brightness Adj:** Adjusts the brightness of the display using the Scroll keys. When complete, press ENTER.

**Contrast Adj:** Adjusts the contrast of the display using the Scroll keys. When complete, press ENTER.

**NOTE:** This feature is usually only required in very cold weather.

**Beep:** Turns the beep on or off.

**Sleep Scope** is a power saving option that shuts down AudioStar and the telescope without forgetting its alignment. With “Sleep Scope” selected, press ENTER to activate the Sleep function. AudioStar goes dark, but the internal clock keeps running. Press any key, except ENTER, to re-activate AudioStar and the telescope.

**Park Scope** is designed for a telescope that is not moved between observing sessions. Align the telescope one time, then use this function to park the telescope. Next time it is powered up, enter the correct date and time – no alignment is required. Pressing ENTER causes the telescope to move to its pre-determined Park position. Once parked, the screen prompts to turn off power.

**IMPORTANT NOTE:** When the “Park Scope” option is chosen and the display prompts you to turn off the telescope’s power, AudioStar is unable to be returned to operation without turning the power off and then back on.

**Language:** Select the English language or other pre-loaded language and AudioStar will display text and audio descriptions in the selected language.

**Audio clip:** Select from Automatic or On Demand. The Automatic setting will automatically play the object audio when a night sky object is selected on the AudioStar. The On Demand feature requires the user to press the ? key once a night sky object is selected. Pressing the ? key will then play the audio presentations for the selected object.

**Cord Wrap,** when set to “On,” moves the telescope in such a way as to prevent the cords and cables attached to your telescope assembly from getting wound around the assembly and tangled as the telescope slews to objects. “Off” is the default setting.

## Setup Menu

The Setup menu’s primary function is to

★ STARNAVIGATOR TIPS ★

### Observing Considerations

- Try to pick an observing site away from street and house lights, and car headlights. While this is not always possible, the darker the site, the better.
- Give your eyes about ten minutes to adjust to the darkness before observing. Give your eyes a rest from observing every ten or fifteen minutes to relieve eyestrain.
- Try not to use a standard flashlight. Seasoned observers use red LED flashlights or tape red cellophane over their flashlights for setup and map reading so they don’t have to continually readjust their eyes to the darkness. Be careful not to shine bright lights if there are other observers in the area. Never shine a flashlight into a telescope while someone is observing!
- Dress warmly. It gets chilly when you’re sitting for prolonged periods, even on some summer nights.
- Practice setting up your equipment during the day or in a lighted area to become familiar with it before going to a dark site.
- Use your 25mm eyepiece to view terrestrial objects and wider areas of space, such as open star clusters. Use your higher power eyepieces when you wish to view something up close, such as craters on the Moon or the rings of Saturn.
- Know your observing site. If you’re going to try out an unfamiliar site, check it out in the daylight for obstructions and pitfalls.



Looking at or near the **Sun** will cause **irreversible** damage to your eye. Do not point this telescope at or near the Sun. Do not look through the telescope as it is moving.

align the telescope (see **EASY ALIGN**, page 21). However, there are numerous other features available within the Setup menu, including:

**Date** changes the date used by AudioStar. This function is useful to check events in the past or future. For example, set the Date menu for a day three months in the future. Then check the “Select Item: Event” menu for the Sunset time on that date. See **EVENT MENU**, page 25.

**Time** changes the time entered into AudioStar. Setting the correct time is critical for AudioStar to properly calculate locations and events. Time may be set to 24-hour mode (military time) by selecting the “blank” option which follows the “AM” and “PM” options.

**Daylight Saving** is used to enable or disable Daylight Savings time.

***NOTE:** Daylight Savings Time may be referred to by different names in various areas of the world. Check local time to verify.*

**Telescope** accesses the several options, including:

- **Model:** Allows you to select the telescope model connected to AudioStar.
- **Focal Length:** Displays the focal length of the selected telescope.
- **Az Ratio and Alt Ratio:** The Az (Azimuth) ratio and Alt (Altitude) ratio refers to the gears of the telescope’s motors. Do not alter these numbers.
- **Az Percent:** The Az (Azimuth) Percent allows you to change the azimuth backlash, *i.e.*, the way the Arrow keys move the telescope along the azimuth (horizontal) axis. If you enter a value near 100, the telescope tube responds more quickly (it responds immediately at 100%) as you hold down an Arrow key and also slews (moves) the tube more quickly. If you enter a value near 0, it takes longer for the tube to respond as you hold down an Arrow key and also slews the tube more slowly. Experiment with this option. Try changing the percent value until you get a “feel” for the Arrow keys that is comfortable for you.
- **Alt Percent:** The Alt (Altitude) Percent operates identical to the Az Percent option (see above), but allows you to change the altitude backlash, *i.e.*, the way the Arrow keys move the telescope when moving along the altitude (vertical) axis.
- **Train Drive:** Trains the Altitude and Azimuth motors to locate objects with more precision.
- If you are experiencing any problems with pointing accuracy, follow the procedure described in **APPENDIX D: TRAINING THE DRIVE**, page 48, to insure accurate pointing and tracking.
- **Tracking Rate:** Changes the speed at which the telescope tracks targets in the sky.
  - a. **Sidereal:** The default setting for AudioStar; sidereal rate is the standard rate at which stars move from East to West across the sky due to the rotation of the Earth.
  - b. **Lunar:** Choose this option to properly track the Moon over long observing sessions.
  - c. **Custom:** Allows entry of user-defined tracking rates.
- **Reverse L/R:** Reverses the functions of the Left and Right Arrow keys (*i.e.*, the Right key moves the telescope to the left).
- **Reverse UP/DOWN:** Reverses the functions of the Up and Down Arrow keys (*i.e.*, the Up key moves the telescope down).
- **Calibrate Motor:** If the telescope motors appear to have a problem, use this option to retest the motors before performing a Reset. This option is also used if an AudioStar unit is moved between telescopes, to match AudioStar to the new telescope. To calibrate the motors, select this option and press ENTER.
- **High Precision:** If High Precision is turned on, when looking for a faint celestial object (*i.e.*, a nebula or galaxy), AudioStar first slews to a nearby bright star and displays “ENTER to Sync.” Center the star in the eyepiece, then press ENTER. At that point the telescope has a high precision alignment to that part of the sky and it then slews to the object that was originally requested.

**Note:** The time and date information is kept by a high precision internal clock, which is set at the factory and held by a long-life lithium battery.

Replace the internal clock’s battery with a CR-2032 lithium battery. This battery is located in the battery compartment.

Both batteries are available from a photographic supply houses or any place lithium batteries are sold.



Looking at or near the **Sun** will cause **irreversible** damage to your eye. Do not point this telescope at or near the Sun. Do not look through the telescope as it is moving.

centered in the eyepiece. If “Terrestrial” is selected, the tracking motor is turned off. To learn how to track an object automatically, see page 19.

**Site** provides access to several options including:

- **Select:** Displays the currently selected observing site. Use the Scroll keys to cycle through all available sites (see **ADD** below). Press ENTER when the site you wish to select displays. Use this option when you move to a different geographic location.
- **Add:** Allows you to add new observing sites to the database (up to six sites may be stored). Scroll through the list of Countries/States. Press ENTER when the site you wish to add displays. Then choose the desired city in the same manner.
  - **Delete:** Deletes a stored site from the database.
  - **Edit:** Edits a selected site, including: the name, latitude, longitude, and time zone. Time Zone refers to the Greenwich Mean Time (GMT) time zone shift. Users West of Greenwich, England use “-” hours, East of Greenwich use “+” hours. For the United States, look up the time zone shift in Table 1.
    - **NOTE:** *AudioStar compensates for daylight savings time, if selected. See **SETUP MENU: DAYLIGHT SAVING**, page 29.*
- **Name:** Users may enter both their first and last names using the Up and Down Arrow keys to cycle through the alphabet. Use the Right and Left Arrow keys to move through the text. Press ENTER when the entry is complete.
- **Address:** Use the Up and Down Arrow keys to enter your street address, city, state, and zip code. Press ENTER when the entry is complete.
- **Download** transfers information from a personal computer or another AudioStar. During the operation, the warning “Downloading Do Not Turn Off” appears.
  - **NOTE:** *The Download function requires the optional #505 Cable Connector Kit. See the instruction sheet included with the kit for more information on how to download. Also see **OPTIONAL ACCESSORIES**, page 39.*
- **Clone** uploads information from one AudioStar handbox to another. Three options are available:
  - **Catalogs:** Sends only user-defined object information, such as new satellite orbits or comet data to another AudioStar handbox.
  - **Software:** Sends only the basic AudioStar software. This is useful if one user has downloaded a new version of AudioStar software from the Meade website ([www.meade.com](http://www.meade.com)) and wants to pass this software along to friends.
  - **All:** Everything, user-defined information and AudioStar software, is sent to another AudioStar.
- **Statistics** provides basic statistical data about AudioStar, including:
  - **Characters Free:** Shows how much room is available in user-defined object memory.
  - **Version:** Shows the current version of the AudioStar software.

Time Zone	Shift
Atlantic	-4 Hours
Eastern	-5 Hours
Central	-6 Hours
Mountain	-7 Hours
Pacific	-8 Hours
Hawaii	-10 Hours

Table 1: Time Zone Shift.

**Reset** completely resets AudioStar. Most values entered into the menus revert to factory defaults. AudioStar requires initialization again after a Reset before proceeding with observations. See **INITIALIZING AudioStar**, page 19.



Looking at or near the **Sun** will cause **irreversible** damage to your eye. Do not point this telescope at or near the Sun. Do not look through the telescope as it is moving.

## Helpful Hints about Getting Started

### Attend a Star Party

A fun way to learn more about astronomy is to join an astronomy club. Check your local newspaper, school, library, internet, or telescope dealer to find out if there's a club in your area.

At club meetings, you will meet other astronomy enthusiasts with whom you will be able to share your discoveries. Clubs are an excellent way to learn more about observing the sky, to find out where the best observing sites are, and to compare notes about telescopes, eyepieces, filters, tripods, and so forth.

Often, club members are excellent astrophotographers. Not only will you be able to see examples of their art, but you may even be able to pick up some "tricks of the trade" to try out on your telescope.

Many groups also hold regularly scheduled Star Parties at which you can check out and observe with many different telescopes and other pieces of astronomical equipment. Magazines such as *Sky & Telescope* and *Astronomy* print schedules for many popular Star Parties around the United States and Canada.

### Observing Considerations

- Try to pick an observing site away from street and house lights, and car headlights. While this is not always possible, the darker the site, the better.
- Give your eyes about ten minutes to adjust to the darkness before observing. Give your eyes a rest from observing every ten or fifteen minutes to relieve eyestrain.
- Try not to use a standard flashlight. Seasoned observers use red LED flashlights or tape red cellophane over their flashlights for setup and map reading so they don't have to continually readjust their eyes to the darkness. Be careful not to shine bright lights if there are other observers in the area. Never shine a flashlight into a telescope while someone is observing!
- Dress warmly. It gets chilly when you're sitting for prolonged periods, even on some summer nights.
- Practice setting up your equipment during the day or in a lighted area to become familiar with it before going to a dark site.
- Use your 25mm eyepiece to view terrestrial objects and wider areas of space, such as open star clusters. Use your higher power eyepieces when you wish to view something up close, such as craters on the Moon or the rings of Saturn.
- Know your observing site. If you're going to try out an unfamiliar site, check it out in the daylight for obstructions and pitfalls.–



Looking at or near the **Sun** will cause **irreversible** damage to your eye. Do not point this telescope at or near the Sun. Do not look through the telescope as it is moving.

# ADVANCED AUDIOSTAR FEATURES

Before trying out the examples in this section, familiarize yourself with the basic operations of AudioStar described earlier in this manual. The following examples assume that you have a basic knowledge of AudioStar and understand how to scroll to a desired menu or menu option, and how to enter numbers and text. It also assumes that you have initialized AudioStar and have placed the telescope in the “Home” position (when appropriate).

## Adding Observing Sites

If you plan to observe using AudioStar at different geographic locations, you can store up to six observation sites in AudioStar’s memory to help simplify your telescope setup. Perform these procedures using the Site options (Add, Select, Delete, Edit) of the Setup menu.

### To Add a Site to the user-defined site list:

In this example, you will choose a city and add it to the database list. You will then select the site to enable it.

1. Navigate to the “Setup: Site” menu. Press ENTER,
2. Scroll through the options until “Site: Add” displays. Press ENTER.
3. Scroll through the list of countries/states. Press ENTER when the country/state you wish to add displays.
4. Scroll through the list of cities. Press ENTER when the city you wish to add displays. The Site is now add to the database. You may add 5 sites using this method (the sixth site is the site you added during the Initialization process)
5. To choose a site, navigate to “Setup: Select.” Press ENTER. Scroll through the list of sites. When the desired site displays, press ENTER.

### To Edit a Site:

In this procedure, you will enter a location that is not available in the AudioStar database by editing data of a nearby site. You will edit the location’s name, latitude, longitude and the time zone shift. You will then select the site to enable it. See page 30 for a table showing the different timezones for North America.

You will need to know the latitude and longitude of your location to perform this procedure.

1. Using the Add option, choose a site on the list that is closest to your observing site and press ENTER so that the site is added to your observing sites list. Choosing a site already on the list (as opposed to using the “Custom” feature) makes it easier to edit, as the “Time Zone” value may not need to be changed.
2. Scroll to “Site: Edit” and press ENTER. “Edit: Name” displays. Press ENTER.
3. The name of the site you have just entered to your list displays; if it does not, scroll to the site.
4. Using the Arrow keys, change the name of the site so that it now reads the name of your observing location. Press ENTER. “Edit: Name” displays again.
5. Press the Scroll Down key and “Edit: Latitude” displays. Press ENTER.
6. Using the Number Keys, enter the latitude of your observing site and then press ENTER. “Edit: Latitude” displays again.
7. Press the Scroll Down key and “Edit: Longitude” displays. Press ENTER.
8. Using the Number Keys, enter the longitude of your observing site and then press ENTER. “Edit: Longitude” displays again.
9. Press the Scroll Down key and “Edit: Time Zone” displays. Press ENTER. (If the site you chose from the list in step 1 has the same Time Zone as the site you are editing, just press ENTER again to go on to the next step.) “Time Zone” refers to the Greenwich Time Zone shift. Users West of Greenwich, use “-” hours (one hour per time zone) and users East of Greenwich use “+” hours. For the United States, look up the shift in **Table 1**.



Looking at or near the **Sun** will cause **irreversible** damage to your eye. Do not point this telescope at or near the Sun. Do not look through the telescope as it is moving.



## How to Create Your Own Guided Tour

When a Guided Tour is selected, AudioStar slews your telescope to a predetermined list of objects and displays information about each object, such as type of object, constellation location, R.A. and Dec coordinates, and so forth. AudioStar contains a few Guided Tours which are programmed at the factory. But it is also possible for an observer to create a custom Guided Tour.

A tour is basically an ASCII text file that contains a list of directions and descriptions. Each line of a tour is either a comment line, a command line, or a description.

### What you will need:

- A PC with text editor or word processing software installed (the tour must be saved as a “text only” or as a “MS-DOS text” file).
- The Meade #505 Cable Connector Kit to download tour information to the AudioStar handbox.

### Tour Modes

The objects chosen for a tour list are selected from AudioStar’s database or by entering the object’s RA and Dec coordinates. The tour is presented in one of two modes:

*Automatic Mode:* The title of an object appears on first line and descriptive text scrolls on line 2.

*Interactive Mode:* Tour name appears on the first line of the AudioStar display and the name of the object displays on line 2. To display descriptive text in this mode, the user must press ENTER.

### Comment Line

Information in the Tour program that is not displayed, such as authorship, revision history, copyrights, etc. All comments begin with a “/” character in column 1 of the line. For example:

```
/ Extreme Objects  
/ (c) 2016 Meade Instruments Corporation
```

### Command Line

This line contains programming commands, including: RA and DEC coordinates, a title string, a description string, and a keyword.

**RA:** Enter the Right Ascension of an object in the following format: HH:MM:SS. *Eg.*, 18:51:05

**Dec:** Enter the Declination of an object in the following format: DDdMMmSSs. *Eg.*, – 06d16m00s

**Title String:** Text within a title string is displayed as the title of the object. A title string can contain up to 16 characters and must be surrounded by quotation marks. For example. “M64” or “My Favorite Star.”

*In Interactive Mode,* the title string appears on line 2 until it is selected with the ENTER key.

*In Automatic Mode,* or after Interactive Mode selection, the title string appears on line 1 while the description scrolls across line 2.

**Keywords:** Action to be performed during a tour. AudioStar recognizes the following keywords:

TITLE	TEXT	USER	NGC
IC	SAO	MESSIER	CALDWELL
PLANET	MOON	SATELLITE	ASTEROID
COMET	LUNAR ECLIPSE	METEOR SHOWER	DEEP SKY
CONSTELLATION	STAR	LANDMARK	DEFINE
PICK ONE/PICK END	AUTO SLEW ON/OFF	#END	

**Description String:** Description of an object. Must be surrounded by quotation marks. If the description is longer than one line, each line must end with a quotation mark and a hard return. Begin the next description line with a quotation mark.

If quotation marks are to be displayed in the on-screen description, use two quote marks at the beginning and end of the desired phrase. For example: “The Orion Nebula is considered “awesome” by many who view it.”



Looking at or near the **Sun** will cause **irreversible** damage to your eye. Do not point this telescope at or near the Sun. Do not look through the telescope as it is moving.

### Writing Your Own Guided Tour

Using the list of commands listed above, a custom tour can be created. Placing the word AUTO SELECT before any of the command lines activates Automatic Mode and, when selected, AudioStar automatically searches and finds the designated object.

The following is a list of command lines, complete with keywords and necessary strings:

#### TITLE

Title must be the first keyword in your tour after any comment lines and must be 15 characters or less. AudioStar displays this title when “Guided Tour” is selected from the menus.

For example: TITLE “A Star’s Life”

TEXT “title string” “description string”

This command allows you to display a text title and description.

USER ra dec “title string” “description string”

This command line allows you to access a specific object with your own description. Enter USER, then the RA and DEC of a desired object, and its title and description. Use the format described in the Command Line section.

The following commands specify objects that are already in the AudioStar database. If these commands follow the command AUTO SELECT, the object’s title displays on line 1 and its description scrolls across line 2.

Do not add a description string after the following command lines; these commands access objects with existing description in the AudioStar database.

#### NGC xxxx

Enter NGC followed by the desired New General Catalog number and AudioStar provides the user with a description of the object from its database. For example: NGC 4256

#### IC xxxx

Enter IC followed by the desired Index Catalog number and AudioStar provides the user with a description of the object from its database. For example: IC 1217

#### SAO xxxxxx

Enter SAO followed by the desired SAO number and AudioStar provides the user with a description of the object from its database. For example: SAO 30200

#### Messier xxx

Enter MESSIER followed by the desired Messier number and AudioStar provides the user with a description of the object from its database. For example: M 101

#### CALDWELL xxx

Enter CALDWELL followed by the Caldwell number and AudioStar provides the user with a description of the object from its database. For example: CALDWELL 17

#### PLANET “name”

Enter PLANET and then the name of the desired planet in quotes. AudioStar provides the user with a description of the selected planet from its database. For example: PLANET “Pluto”

#### MOON

This command accesses information about the Moon from the AudioStar database.

#### SATELLITE “name”

Enter SATELLITE and then the name of the desired satellite in quotes. AudioStar displays information about the satellite from its database. For example: SATELLITE: “Intl Space Stn”

#### ASTEROID “name”

Enter ASTEROID and then the name of the desired asteroid in quotes. AudioStar displays information about the asteroid from its database. For example: ASTEROID: “Ceres”



Looking at or near the **Sun** will cause **irreversible** damage to your eye. Do not point this telescope at or near the Sun. Do not look through the telescope as it is moving.

#### COMET "name"

Enter COMET and then the name of the desired comet in quotes. AudioStar displays information about the comet from its database. For example: COMET: "Halley"

#### LUNAR ECLIPSE

If LUNAR ECLIPSE is part of the tour, AudioStar checks its database every time the tour is activated to see if a lunar eclipse is visible that evening. If no eclipse is visible, this option is skipped and the tour proceeds on to the next object.

#### METEOR SHOWER

If METEOR SHOWER is part of the tour, AudioStar checks its database every time the tour is activated to see if a meteor shower is visible that evening. If no meteor shower is visible, this option is skipped and the tour proceeds on to the next object.

#### DEEP SKY "name"

Enter DEEP SKY followed by the name of the desired object in quotes. For example:  
DEEP SKY "Small Magellanic Cloud"

#### CONSTELLATION "name"

Enter CONSTELLATION followed by the name of the desired constellation in quotes. For example: CONSTELLATION "Leo Major"

#### STAR "name"

Enter STAR followed by the name of the desired star in quotes. For example: STAR "Vega"

#### LANDMARK az alt "title" "description"

Enter the azimuth (az) for the desired object in the following format: xxxdxxmxxs. For example: 123d27m00s. Then enter the altitude of the desired object in the following format: xdxmxxs. Then enter the title string and description string in quotes. For example:

LANDMARK 123d27m00s 57d20m20s "Landmark 1" "North corner of apartment building"

#### PICK ONE / PICK END

These two statements are used to surround a list of items that AudioStar can choose from during a tour. AudioStar begins at the top of the PICK ONE list and displays the first object from the list that is above the horizon and ignores the rest.

This statement is useful for developing tours that can be presented year round. For each object type you wish to use to illustrate in your tour, pick 10 to 12 examples spaced across the range of right ascension. Bracket them by the PICK ONE / PICK END statements. One current example displays for the user. For example:

AUTO SELECT TEXT "Globular Cluster" "Globular clusters are huge balls of stars."

"They contain 50,000 to 100,000 stars and are located on the fringes of our"

"galaxy."

PICK ONE

AUTO SELECT MESSIER 13

AUTO SELECT MESSIER 15

AUTO SELECT MESSIER 92

AUTO SELECT MESSIER 4

AUTO SELECT MESSIER 68

AUTO SELECT NGC 1234

AUTO SELECT TEXT "None Available" "I'm sorry. There are no bright globular"

"clusters visible at this time."

PICK END

#### AUTO SLEW ON / AUTO SLEW OFF

With AUTO SLEW ON enabled in the tour, AudioStar automatically slews the telescope to objects first before displaying the text description. This feature is useful when designing tours in which observing certain objects is required. For example, an astronomy professor may require his



Looking at or near the **Sun** will cause **irreversible** damage to your eye. Do not point this telescope at or near the Sun. Do not look through the telescope as it is moving.

students to observe six objects, four of which AudioStar automatically slews to in a tour. The students would have to manually slew to the last two objects. He would then place AUTO SLEW ON before his first required object and AUTO SLEW OFF after the fourth object.

#END

To end a tour, type the command #END on a separate line at the very end of the tour.

### Downloading Tours

Once a tour is written and stored as an ASCII file (saved either as a “text only” or “MS DOS text” file), load it into AudioStar using the AudioStar Update Utility on your PC. As tours are downloaded into the handbox, AudioStar examines the programming. If it doesn’t understand the terminology used within a tour, it flags questionable areas and displays them in a pop-up window on your computer screen. Make the necessary corrections and try to download again. See the instruction sheet with your #505 Cable Connector Kit for more information about downloading data to and interfacing with AudioStar.

### Landmarks

This menu option allows you to define and store terrestrial objects in the Landmark database. First, a landmark needs to be stored in memory using the “Landmark: Add” option. To view a landmark, use the “Landmark: Select” option. Landmarks may also be viewed using the “Landmark Survey” option in the Utilities menu.

#### To Add a landmark to the database:

In this procedure, you will store the location of terrestrial landmarks in AudioStar’s memory.

1. Set the telescope in the home position, if necessary. Note for future reference where the telescope is located and if you have aligned the telescope, which alignment method is used.  
**IMPORTANT NOTE:** *To use the Landmark function, the telescope must be located and aligned exactly as when the landmark(s) was added to the database.*
2. Display the “Setup: Targets” menu option. Chose “Terrestrial” and press ENTER. “Setup: Targets” displays again. Choosing this option turns off tracking for astronomical objects and is not useful for the viewing of terrestrial objects such as those in the Landmark database. Be sure to change this option back to “Astronomical” when you wish to view celestial objects again.
3. Press MODE once. “Select Item: Setup” displays.
4. Press the Scroll Down key once and “Select Item: Object” displays. Press ENTER. “Object: Solar System” displays.
5. Press the Scroll Up key twice and “Object: Landmarks” displays. Press ENTER. “Landmark: Select” displays.
6. Press the Scroll Down key once. “Landmark: Add” displays. Press ENTER.
7. “Landmark Name” displays. Using Arrow keys, enter a name for the landmark you wish to add to the database. When finished, press ENTER.
8. “Center Landmark. Press Enter” displays. Using only the Arrow keys (do not manually move the telescope), move the telescope to the desired landmark and center the object in the eyepiece. Press ENTER. The object is now stored in memory.
9. “Landmark: Add” displays. If you wish to add more landmarks, repeat steps 5 through 7.

#### To Select a landmark from the database:

1. Make sure the telescope is located and aligned exactly as when the desired landmark was entered into memory.



Looking at or near the **Sun** will cause **irreversible** damage to your eye. Do not point this telescope at or near the Sun. Do not look through the telescope as it is moving.

2. Display the “Landmark: Select” menu option. Press ENTER.
3. Use the Scroll keys to scroll through the list of objects you have previously entered. When the desired object displays, press ENTER to select the object. Use the Scroll keys to scroll through location information about the object, if desired. Press GO TO to slew the telescope to the landmark.
4. Press MODE to exit.

**To perform a Landmark Survey**

This procedure allows you to perform a tour of the objects entered in the “Object: Landmark” menu option—note that the Landmark Survey will function only if you have previously entered objects in the Landmark menu.

1. Navigate to “Utilities: Landmark Survey” menu and press ENTER.
2. “Landmark Survey: Slewing...” displays. The telescope moves to the first object on the Survey list and displays the name of the object.
3. Press MODE to pause the Survey. Press ENTER to restart the survey at the first object of the survey.

**To check on the available amount of memory in AudioStar.**

AudioStar has a limited amount of memory. Once you begin to store Landmarks, User Objects and other bits of information in AudioStar, you will begin to use up memory. This procedure allows you to check on how much memory is still available.

1. Navigate to the “Setup: Statistics” menu option and press ENTER.
2. “Statistics: 37.2K Char. Free” displays. This is the amount of memory that is still available to the user.

**Identify**

This procedure allows you to use AudioStar to identify objects you have found in the night sky using the Arrow keys. If the object is not in AudioStar’s database, AudioStar displays information about an object in its database that is closest to the one you queried about.

**IMPORTANT NOTE:** *For this function to operate properly, you must first set the telescope in the home position and initialize AudioStar. If you physically move the telescope after initialization, this function will fail to operate properly.*

In this procedure, you will center an object you wish to have identified by AudioStar in the telescope eyepiece and use the “Identify” menu to find out information about the object or the nearest object to it in the AudioStar database.

1. Center the object you wish to have identified in the telescope’s eyepiece.
2. Navigate to the “Object: Identify” option and press ENTER.
3. “Searching...” displays. When AudioStar finishes calculating, the name of the closest object displays.
4. Press a Scroll key to display information about this object. AudioStar displays some or all the following information about the object with each press of a Scroll key:

**Displayed information:**

Catalog or common name of object  
 Type of object  
 Right Ascension  
 Declination  
 Constellation  
 Magnitude  
 Size  
 Scrolling message

**Example:**

Messier 107, NGC6171, Orion Nebula, etc  
 Globular Cluster, Nebula, Black Hole, etc.  
 16:32:4  
 13°03’  
 Virgo, Orion, etc.  
 3  
 2’  
 “This Globular Cluster is 10,000 light years away....”



## Browse

**This menu** allows you to search the database for objects with certain parameters, much like a search engine. “Edit Parameters” lets you set various parameters for the search, and “Start Search” activates the search. A typical search might be performed as follows:

1. Select “Browse” from the Object menu. Press ENTER. “Browse: Start Search” displays.
2. Press one of the Scroll Keys and “Browse: Edit Parameters” displays. Press ENTER.
3. “Edit Parameters: Largest (mins)” displays. “Mins” stands for arc-minutes. Press ENTER.
4. “Largest (mins)” and a value displays. Using the Number keys, enter a size in arc-minutes. AudioStar will search for objects *up to* this size and no larger. Press ENTER.
5. “Edit Parameters: Largest (mins)” displays again. Press the Scroll Down key. “Edit Parameters: Smallest (mins)” displays. Enter the value for the smallest size of an object that AudioStar will search for in the database. Continue with “Brightest,” Faintest,” and “Minimum Elevation,” using the procedure described in steps 3 and 4.
6. After “Minimum Elevation,” “Object Type” displays. Press ENTER. “+Black Hole” displays. If you do *not* wish to have “Black Holes” in your search, press ENTER and the “+” changes to a “-.” Press the Scroll Down to scroll to the next item. “+Diffuse Nebula” displays. Continue to scroll through the list and press ENTER if you wish to change the “+” to a “-” or vice-versa.
7. After you have scrolled to the last item on the “Object Type” list, press MODE twice and the Scroll Down key once. “Browse: Start Search” displays. Press ENTER. “Start Search: Next” displays. Press ENTER. AudioStar searches the database and displays the first object that matches the search parameters you have entered. Use the scroll keys to display information about the object. Press MODE and “Start Search: Next” displays again. Press ENTER and the next item matching the parameters displays. Repeat this procedure to display all the objects.
8. Press MODE repeatedly to leave this menu.

## StarNavigator NG

### Look into the Future

The AudioStar Date menu option in the Setup menu is much more than just an entry of today’s date; with it you can look far into the future or learn about past events. AudioStar can calculate the date and times of future events and, except for eclipses, past events as well (based on the current calendar system). *E.g.*, a Sunrise on March 6, 2043 A.D. or the Vernal Equinox in 1776 A.D. To use this feature, enter the desired date in the Setup menu and select an option in the Event menu.

AudioStar can calculate dates and times for Sunrises, Sunsets, Moonrises, Moonsets, Moonphases, Solar and Lunar Eclipses (for the next 100 years), meteor showers, equinoxes and solstices, and the minimums of Algol.

One very practical use of the date menu is to check the Sunset option to determine when you can begin your astronomical observing.



Looking at or near the **Sun** will cause **irreversible** damage to your eye. Do not point this telescope at or near the Sun. Do not look through the telescope as it is moving.

# OPTIONAL ACCESSORIES

A wide assortment of professional Meade accessories is available for the StarNavigator NG Series Telescopes. The premium quality of these accessories is well-suited to the quality of the instrument itself. **Consult Meade.com for complete details on these and other accessories.**

- **Series 4000 Super Plössl (SP) Eyepieces:** Yields high-resolution imaging with all StarNavigator NG telescope models. A useful selection includes the SP 15mm and SP 12.4mm eyepieces.
- **HD-60 Eyepieces:** The All New Series 5000 HD-60 Eyepieces have a large 60 degree Apparent Field of View that is flat and sharp to the edge, 17mm or more of eye relief for easy comfortable observing, Super Fully- Multi-Coated lenses with blackened edges, rotating adjustable.
- **#905 Variable Polarizer (1.25"):** The #905 system includes two polarizer filters mounted in a specially machined cell, for glare-reduction in observing the Moon. Rotate the thumbscrew at the side of the unit to achieve light transmission between 5% and 25% of its original value. The #905 inserts into the diagonal mirror of the telescope, followed by an eyepiece.
- **07584 Universal Power Adapter:** Permits powering from a standard home (115v AC outlet).
- **Cigarette Lighter Adapter:** Powers the telescope by means of an automobile cigarette lighter plug.
- **LXPS Power Pack:** Powers the telescope by means of a lead-acid portable battery.
- **#126 2x Barlow Lens (1.25"):** Doubles each eyepiece power while maintaining excellent image corrections. For example, a 9mm eyepiece used with the model StarNavigator NG yields a power of 78X; when used in conjunction with the #126 Barlow lens, the same eyepiece yields 156X.
- **Camera Adapter:** StarNavigator NG Series Telescopes may be used for through-the-telescope photography of the Moon and planets or for terrestrial objects. For eyepiece-projection photography with any of these telescopes, use the Basic Camera Adapter (1.25").
- **#505 Cable Connector Kit & Autostar Suite Software:** Displays more than 15,000 celestial wonders – galaxies, nebulae, star clusters, stars, and planets – on your PC, enabling even the beginner to locate and identify objects to observe with the telescope or to print out star charts for use in observing sessions. Operates with any Windows™-based personal computer. The Cable Connector Kit permits connection of any StarNavigator NG telescope model, AudioStar, and PC, for downloading of new software to AudioStar or for updating of Earth satellite or other celestial object positions.
- **Meade Series 4000 #3200 Lunar And Planetary Color Filter Set:** Color filters are considered by many to be an essential “must have” for observing and imaging the Moon and planets. The Model 3200 Lunar and Planetary Filter Set includes the following filters:
  - #25A Red (14% Transmission) - for sharp contrast in Jupiter's cloud belts, helps define polar caps and maria on Mars. Best for larger telescopes due to restricted transmission.
  - #12 Yellow (74% Transmission) - this filter adds contrast to blues, enhances reds and yellows on Jupiter and Saturn, and increases contrast on Mars and on the Moon
  - #80A Blue (30% Transmission) - this is a popular filter for enhancing spiral features in Jupiter's cloud belt including the Red Spot and adding contrast to Saturn and the Moon.
  - Moon Filter ND96 (13% transmission) - reduces glare when observing the Moon.
- **LPI-G Lunar, Planetary Imager and Guiding Camera:** The LPI-G is an excellent camera for auto-guiding and solar system astrophotography. With our solar, lunar and planetary guide camera, experience the universe on a whole new level. Lightweight and portable, LPI-G comes with a 1280 x 960 pixel CMOS sensor with the ability of capturing 28 frames per second at full resolution. This camera has a USB 2.0 connection and is offered with monochrome or color sensors. **Note:** the guiding feature is not compatible with the Meade StarNavigator NG.



Looking at or near the **Sun** will cause **irreversible** damage to your eye. Do not point this telescope at or near the Sun. Do not look through the telescope as it is moving.

# CARING FOR YOUR TELESCOPE

Your StarNavigator NG telescope is a precision optical instrument designed to yield a lifetime of rewarding observations. Given the care and respect due any precision instrument, your telescope will rarely, if ever, require factory servicing. Maintenance guidelines include:

- a. Avoid cleaning the telescope's optics: a little dust on the front surface of the telescope's correcting lens causes virtually no degradation of image quality and should not be considered reason to clean the lens.
- b. When absolutely necessary, dust on the front lens should be removed with gentle strokes of a camel hair brush or blown off with an ear syringe (available at any pharmacy). DO NOT use a commercial photographic lens cleaner.
- c. Organic materials (e.g., fingerprints) on the front lens may be removed with a solution of 3 parts distilled water to 1 part isopropyl alcohol. You may also add 1 drop of biodegradable dishwashing soap per pint of solution. Use soft, white facial tissues and make short, gentle strokes. Change tissues often.

**CAUTION:** Do not use scented or lotioned tissues or damage could result to the optics.

- d. If used outdoors on a humid night, water condensation on the telescope surfaces will probably result. While such condensation does not normally cause any damage to the telescope, it is recommended that the entire telescope be wiped down with a dry cloth before the telescope is packed away. Do not, however, wipe any of the optical surfaces. Rather, simply allow the telescope to sit for some time in the warm indoor air, so that the wet optical surfaces can dry unattended.
- e. If your telescope is not to be used for an extended period, perhaps for one month or more, it is advisable to remove the batteries from the telescope. Batteries left in the telescope for prolonged periods may leak, causing damage to the telescope's electronic circuitry.
- f. Do not leave the telescope inside a sealed car on a warm summer day; excessive ambient temperatures can damage the telescope's internal lubrication and electronic circuitry.

## Collimation (Reflecting Telescopes Only)

StarNavigator NG refracting telescopes are optically aligned (collimated) at the factory prior to shipment, and it is never necessary to re-collimate the optics of these models. Meade reflecting telescope models are also factory-aligned, but may occasionally require re-alignment, particularly if the telescope has received rough handling in shipment. Before using one of these models for the first time, check the alignment of the optics as outlined in this section. Good optical alignment is essential to get the best optical performance from your telescope.

The optical systems of Meade StarNavigator NG reflecting telescopes include the following parts: primary mirror (1, Fig. 23); secondary mirror (2, Fig. 23); secondary mirror-holder (3, Fig. 23); secondary mirror-vanes (4, Fig. 23) and (1, Fig. 24); primary mirror-tilt screws (5, Fig. 23). The telescope's image is brought to a focus at (6, Fig. 23).

1. **Confirm alignment** - To confirm optical alignment look down the focuser drawtube (1, Fig. 26) with the eyepiece removed. The edge of the focuser drawtube frames reflections of the primary mirror (2, Fig. 26), the secondary mirror (3, Fig. 26), the three ("spider") vanes (4, Fig. 26) holding the secondary mirror, and the observer's eye (5, Fig. 26). With the optics properly aligned, all of these reflections appear concentric (centered), as shown in Fig. 26. Any deviation from concentricity of any of these telescope parts with the eye requires adjustments to the secondary mirror-holder (Fig. 24) and/or the primary mirror cell (Fig. 25,) as described below.
2. **Secondary mirror-vane adjustments:** If the secondary mirror (1, Fig. 27) is left or right of center within the drawtube (2, Fig. 27), slightly loosen the 3-vane adjustment/lock knobs (1, Fig. 24) located on the outside surface of the main tube and slide the entire secondary mirror-holder system up or down in the slotted holes of the main tube until the secondary mirror is centered in the drawtube. If the secondary mirror (1, Fig. 27) is above- or below-center within the drawtube,



Looking at or near the **Sun** will cause **irreversible** damage to your eye. Do not point this telescope at or near the Sun. Do not look through the telescope as it is moving.



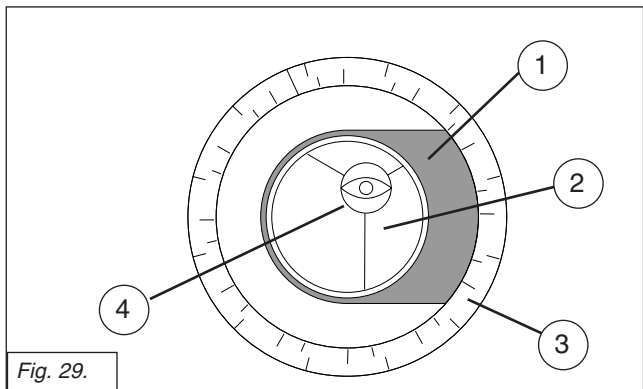
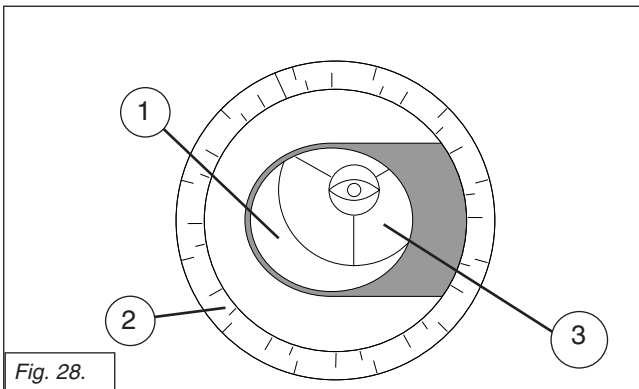
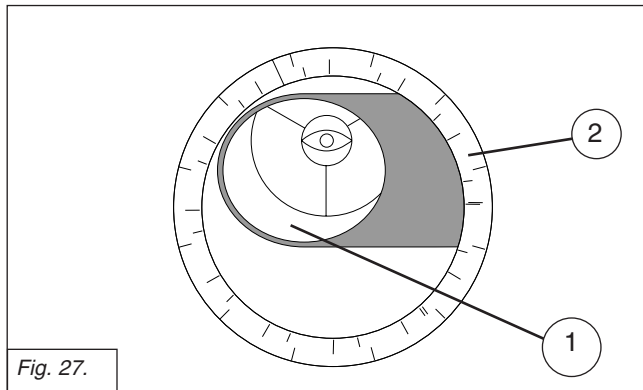
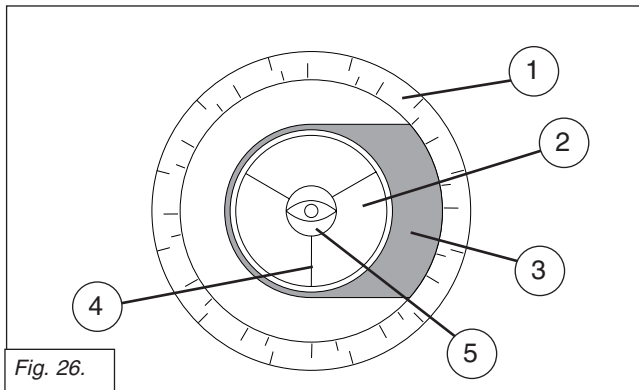
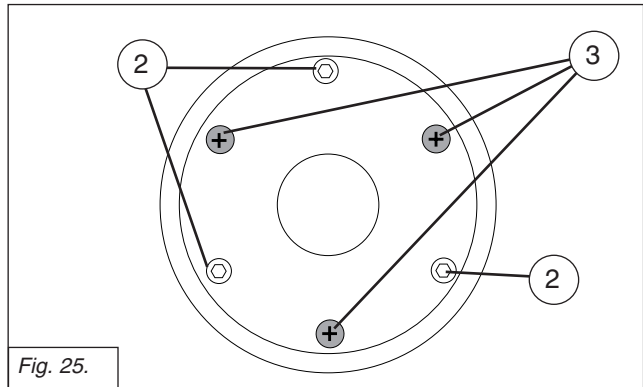
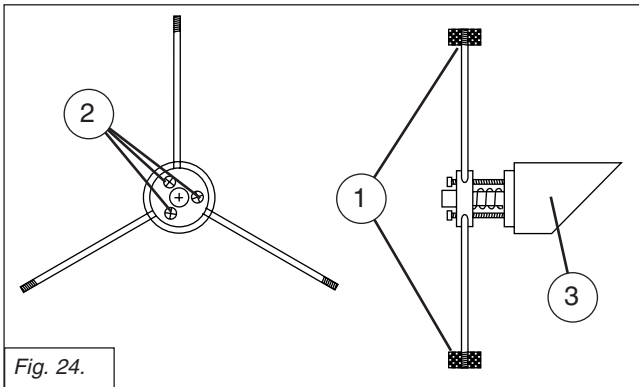
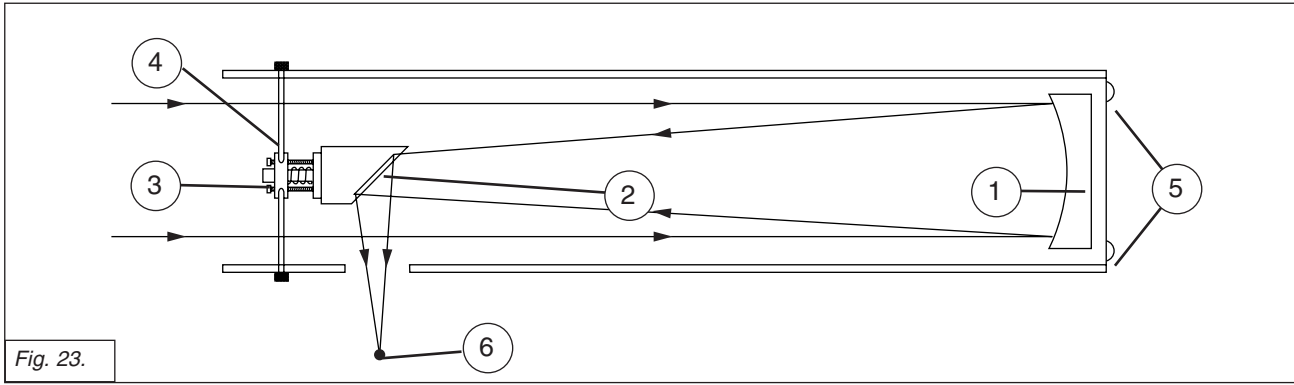

 Looking at or near the **Sun** will cause **irreversible** damage to your eye. Do not point this telescope at or near the Sun. Do not look through the telescope as it is moving.

thread inward one of the adjustment/lock knobs (1, Fig. 24) while unthreading another of these knobs. Only make adjustments to two knobs at a time until the secondary mirror appears as in Fig. 28.

3. *Secondary mirror-holder adjustments:* If the secondary mirror (1, Fig. 28) is centered in the focuser drawtube (2, Fig. 28), but the primary mirror is only partially visible in the reflection (3, Fig. 28), the three “+” (Phillips head) secondary mirror-tilt screws (2, Fig. 24) should be slightly unthreaded to the point where the secondary mirror-holder (3, Fig. 24) can rotate about its axis parallel to the main tube. Grasp the secondary mirror-holder (avoid touching the mirror surface!) with your hand and rotate it until, looking through the drawtube, you can see the primary mirror centered as well as possible in the reflection of the secondary mirror. With the rotation of the secondary mirror-holder at this best-possible position, thread in the three Phillips head screws (2, Fig. 24) to lock the rotational position. Then, if necessary, make adjustments to these three Phillips head screws to refine the tilt-angle of the secondary mirror, until the entire primary mirror can be seen centered within the secondary mirror’s reflection. With the secondary mirror thus aligned the image through the drawtube appears as in Fig. 29.

4. *Primary mirror adjustments:* If the secondary mirror (1, Fig. 29) and the reflection of the primary mirror (2, Fig. 29) appear centered within the drawtube (3, Fig. 29), but the reflection of your eye and the reflection of the secondary mirror (4, Fig. 29) appear off-center, then the primary mirror tilt requires adjusting, using the Phillips head screws of the primary mirror cell (3, Fig. 25). These primary mirror-tilt screws are located behind the primary mirror, at the lower end of the main tube. See Fig. 25. Before adjusting the primary mirror-tilt screws, first unscrew by several turns (use either a hex wrench or pliers) the three hex-head primary mirror lock screws (2, Fig. 25) which are also located on the rear surface of the primary mirror cell and which alternate around the cell’s circumference with the three Phillips head screws. Then by trial and error turn the primary mirror Phillips head tilt screws (3, Fig. 25) until you develop a feel for which way to turn each screw to center the reflection of your eye in the drawtube. (An assistant is helpful in this operation.) With your eye centered as shown in Fig. 26, turn the three hex head primary mirror lock screws (2, Fig. 25) to re-lock the tilt-angle of the primary mirror.

The telescope’s optical system is now aligned, or collimated. This collimation should be re-checked from time to time, with small adjustments (per steps 1, 2, and/or 3, above) effected as required to keep the optics well-aligned.

## Meade Consumer Solutions

If you have a question concerning your StarNavigator NG Telescope, contact the Meade Instruments Consumer Solutions Department at:

**Telephone:** (800) 626-3233

Consumer Solutions hours are 7:00 AM to 4:00 PM, Pacific Time, Monday through Friday. In the unlikely event that your StarNavigator NG telescope requires factory servicing or repairs, write or call the Meade Consumer Solutions Department first, before returning the telescope to the factory, giving full particulars as to the nature of the problem, as well as your name, address, and daytime telephone number. The great majority of servicing issues can be resolved by telephone, avoiding return of the telescope to the factory.



Looking at or near the **Sun** will cause **irreversible** damage to your eye. Do not point this telescope at or near the Sun. Do not look through the telescope as it is moving.

# SPECIFICATIONS

## STARNAVIGATOR NG 90

Optical design.....	Refractor
Clear aperture .....	90mm
Focal length.....	900mm
Focal ratio .....	f/10
Resolving power.....	1.3 arc secs
Max power.....	300X
Mounting.....	Single-arm, motorized Alt-Az
Alignment .....	Altazimuth
Slew Speeds .....	1x sidereal to 5.5°/sec in 9 increments
Tripod .....	Aluminum, adjustable w/ accessory tray

## STARNAVIGATOR NG 102

Optical design.....	Refractor
Clear aperture .....	102mm
Focal length.....	660mm
Focal ratio .....	f/6.5
Resolving power.....	1.3 arc secs
Max power.....	300X
Mounting.....	Single-arm, motorized Alt-Az
Alignment .....	Altazimuth
Slew Speeds .....	1x sidereal to 5.5°/sec in 9 increments
Tripod .....	Aluminum, adjustable w/ accessory tray

## STARNAVIGATOR NG 114

Optical design.....	Reflector
Clear aperture .....	114mm
Focal length.....	1000mm
Focal ratio .....	f/8.7
Resolving power.....	1 arc sec
Max power.....	325X
Mounting.....	Single-arm, motorized Alt-Az
Alignment .....	Altazimuth
Slew Speeds .....	1x sidereal to 5.5°/sec in 9 increments
Tripod .....	Aluminum, adjustable w/ accessory tray

## STARNAVIGATOR NG 130

Optical design.....	Reflector
Clear aperture .....	130mm
Focal length.....	1000mm
Focal ratio .....	f/7.7
Resolving power.....	0.9 arc sec
Max power.....	350X
Mounting.....	Single-arm, motorized Alt-Az
Alignment .....	Altazimuth
Slew Speeds .....	1x sidereal to 5.5°/sec in 9 increments
Tripod .....	Aluminum, adjustable w/ accessory tray

 Looking at or near the **Sun** will cause **irreversible** damage to your eye. Do not point this telescope at or near the Sun. Do not look through the telescope as it is moving.

**STARNAVIGATOR NG 90MAK**

Optical design..... Maksutov-Cassegrain  
Clear aperture ..... 90mm  
Focal length..... 1250mm  
Focal ratio ..... f/13.9  
Resolving power..... 1.3 arc secs  
Max power..... 300X  
Mounting..... Single-arm, motorized Alt-Az  
Alignment ..... Altazimuth  
Slew Speeds ..... 1x sidereal to 5.5°/sec in 9 increments  
Tripod ..... Aluminum, adjustable w/ accessory tray  
accessory tray

**STARNAVIGATOR NG 125MAK**

Optical design..... Maksutov-Cassegrain  
Clear aperture ..... 125mm  
Focal length..... 1900mm  
Focal ratio ..... f/15  
Resolving power..... 0.9 arc secs  
Max power..... 350X  
Mounting..... Single-arm, motorized Alt-Az  
Alignment ..... Altazimuth  
Slew Speeds ..... 1x sidereal to 5.5°/sec in 9 increments  
Tripod ..... Aluminum, adjustable w/ accessory tray

 Looking at or near the **Sun** will cause **irreversible** damage to your eye. Do not point this telescope at or near the Sun. Do not look through the telescope as it is moving.

# APPENDIX A

## Celestial Coordinates

It is helpful to understand how to locate celestial objects as they move across the sky.

A celestial coordinate system was created that maps an imaginary sphere surrounding the Earth upon which all stars appear to be placed. This mapping system is similar to the system of latitude and longitude on Earth surface maps.

In mapping the surface of the Earth, lines of longitude are drawn between the North and South Poles, and lines of latitude are drawn in an East-West direction, parallel to the Earth's equator. Similarly, imaginary lines have been drawn to form a latitude and longitude grid on the celestial sphere. These lines are known as **Right Ascension** and **Declination**.

The celestial map also contains two poles and an equator just like a map of the Earth. The poles of this coordinate system are defined as those two points where the Earth's north and south poles (*i.e.*, the Earth's axis), if extended to infinity, would cross the celestial sphere. Thus, the North Celestial Pole (1, Fig. 30) is that point in the sky where an extension of the North Pole intersects the celestial sphere. This point in the sky is located very near the North Star, Polaris. The celestial equator (2, Fig. 30) is a projection of the Earth's equator onto the celestial sphere.

So just as an object's position on the Earth's surface can be located by its latitude and longitude, celestial objects may also be located using Right Ascension and Declination. For example, you could locate Los Angeles, California, by its latitude (+34°) and longitude (118°). Similarly, you could locate the constellation Ursa Major (the Big Dipper) by its Right Ascension (11hr) and its Declination (+50°).

- **Right Ascension (R.A.):** This celestial version of longitude is measured in units of hours (hr), minutes (min) and seconds (sec) on a 24-hour "clock" (similar to how Earth's time zones are determined by longitude lines). The "zero" line was arbitrarily chosen to pass through the constellation Pegasus — a sort of cosmic Greenwich meridian. R.A. coordinates range from 0hr 0min 0sec to 23hr 59min 59sec. There are 24 primary lines of R.A., located at 15-degree intervals along the celestial equator. Objects located further and further East of the zero R.A. grid line (0hr 0min 0sec) carry higher R.A. coordinates.
- **Declination (Altitude):** This celestial version of latitude is measured in degrees, minutes, and seconds (*e.g.*, 15° 27' 33"). Dec. locations north of the celestial equator are indicated with a plus (+) sign (*e.g.*, the Dec. of the North celestial pole is +90°). Dec. locations south of the celestial equator are indicated with a minus (-) sign (*e.g.*, the Dec. of the South celestial pole is -90°). Any point on the celestial equator (such as the the constellations of Orion, Virgo, and Aquarius) is said to have a Declination of zero, shown as 0° 0' 0."

## Locating the Celestial Pole

To get basic bearings at an observing location, take note of where the Sun rises (East) and sets (West) each day. After the site is dark, face North by pointing your left shoulder toward where the Sun set. To precisely point at the pole, find the North Star (Polaris) by using the Big Dipper as a guide (Fig. 31).

**IMPORTANT NOTE:** For almost all astronomical observing requirements, approximate settings are acceptable. Do not allow undue attention to precise alignment of the telescope to interfere with your basic enjoyment of the instrument.

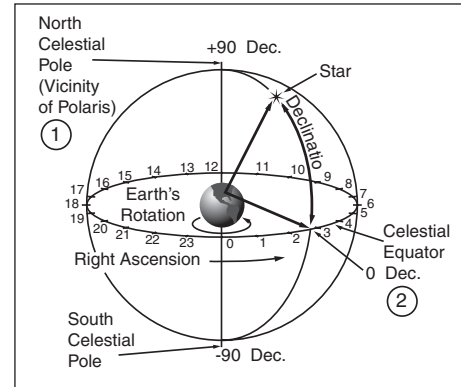

Fig. 30: Celestial Sphere.

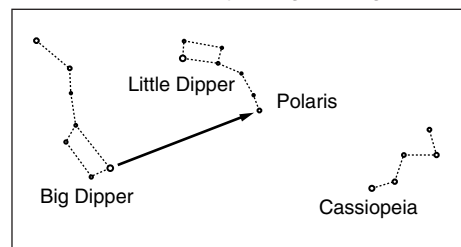

Fig. 31: Locating Polaris.

 Looking at or near the Sun will cause irreversible damage to your eye. Do not point this telescope at or near the Sun. Do not look through the telescope as it is moving.

## APPENDIX B

### Using AudioStar to Find Objects Not in the Database

Although AudioStar contains a database of more than 30,000 celestial objects (stars, nebulae, planets, etc.) that you can observe, you may eventually want to view objects that are not part of the database. AudioStar provides a feature that allows you to enter an object's R.A and Dec. coordinates in the "User: Objects" option of the Object menu and allows automatic slewing of the telescope to the user-entered coordinates.

In order to use this menu option, you first need to look up the R.A and Dec. coordinates of the object or objects you wish to observe. Check out your local library, computer store, bookstore, CD Roms, Internet, or magazines (such as *Sky & Telescope* or *Astronomy*), to find coordinates of celestial objects. The objects/coordinates you enter become part of your own permanent database, called "User Objects."

#### To enter coordinates of an object into the "User: Objects" option of the Object menu:

1. Make sure AudioStar has been initialized and the telescope has been aligned.
2. After the telescope is aligned, "Select Item: Object" displays. (If necessary, use the Scroll keys to scroll through the menus, as previously described, to find this option.) Press ENTER.
3. "Object: Solar System" displays. Keep pressing the Scroll Up key until "Object: User Object" displays and press ENTER.
4. "User Object: Select" displays. Press the Scroll Down key once. "User Object: Add" displays. Press ENTER.
5. "Name" displays on the top line and a blinking cursor on the second line. Use the Arrow keys, as previously described, to enter the name of the object you wish to add to the database. When you are finished, press ENTER.
6. "Right Asc.: 00.00.0" displays. Use the Number keys to enter the digits for the Right Ascension coordinate of your object. When you are finished, press ENTER.
7. "Declination: +00°.00" displays. Use the Number keys to enter the digits for the Declination coordinate of your object. If necessary, use the Scroll Keys to change "+" to "-." When you are finished, press ENTER.
8. AudioStar then prompts you to enter the size of the object. This step is optional. Use the Number keys to enter the size (in arc-minutes), if so desired, and press ENTER to go to the next display. If you do not wish to enter this information, simply press ENTER.
9. AudioStar then prompts you to enter the magnitude of the object. This step is also optional. Use the Number keys to enter this information, if so desired, and press ENTER to go to the next display. "User Object: Add" displays again.

#### To GO TO a user-entered object:

In this procedure, you will choose an object from the User Object list and GO TO the object.

1. With "User Object: Add" displayed, press the Scroll Up key once. "User Object: Select" displays. Press ENTER.
2. Use the Scroll keys (if necessary) to scroll to the desired object. Press ENTER.
3. The name of the object and the Right Ascension and Declination coordinates display.
4. Press GO TO and the telescope slews to the object.

#### **TIP:**

#### **Entering R.A. and Dec. Coordinates of an object without using the menus:**

*If you do not wish to navigate through the menus, a more direct way to enter coordinates is to press and hold MODE for two seconds or more. R.A. and Dec. coordinates display. Press GO TO. "Object Position" and a set of coordinates displays. Enter the R.A. and Dec. coordinates of any celestial object using the Number keys, overwriting the coordinates currently displayed. As soon as the coordinates are entered, AudioStar slews the telescope to the coordinates. Note that the telescope must be initialized and placed in the Alt/Az home position (see page 16) for this procedure to operate properly.*

*However, if you wish to store the coordinates of an object in memory, use the method described at the right.*



Looking at or near the **Sun** will cause **irreversible** damage to your eye. Do not point this telescope at or near the Sun. Do not look through the telescope as it is moving.

# APPENDIX C

## Observing Satellites

In this procedure, you will prepare your telescope to observe a satellite pass.

1. Go to the “Object: Satellite” menu option and press ENTER.
2. Use the Scroll keys to scroll through the list of satellites.
3. Select a satellite from the list and press ENTER.
4. “Calculating....” and then “Tracking...” displays. If the satellite is going to make a pass, “Located” displays.
5. Use the Scroll keys to display data about the pass: aos – acquisition of signal and los – loss of signal. If you subtract the aos from the los, you can calculate how long the satellite will be visible. Location information also displays.
6. “Alarm” displays after the location information. Press ENTER and AudioStar automatically sets the alarm to sound a minute before the satellite’s scheduled appearance. You may return to regular observations until the alarm goes off.
7. When the alarm goes off, return to the Satellite menu and press a Scroll key until the desired satellite is on the top line of the display.
8. Press GO TO. AudioStar slews the telescope to where the satellite should appear. The motor drive stops and a countdown is displayed.

**NOTE:** *If the scheduled appearance position of the satellite is obstructed (i.e., by a building, tree, or hill), press ENTER and AudioStar starts to move the telescope along the expected satellite track. When the track clears the obstruction, press ENTER again to pause the telescope, then continue with this procedure.*

9. With about 20 seconds left on the countdown timer, start watching through the telescope viewfinder for the satellite to enter the field of view.
10. When the satellite enters the viewfinder field of view, press ENTER. The telescope starts to track with the satellite.
11. Use the AudioStar Arrow keys to center the object in the viewfinder, then look through the eyepiece to view the object.

Satellite orbits change and new satellites (including the Space Shuttle) are launched. Visit the Meade website ([www.meade.com](http://www.meade.com)) approximately once a month to get updated information and instructions on how to download this data to AudioStar. If orbital parameters are more than one month old, the satellite pass may not happen at the time predicted by AudioStar. Downloading requires the optional #505 Autostar Software and Cable Connector Kit. See **OPTIONAL ACCESSORIES**, page 35.

**NOTE:** *Satellite observing is an exciting challenge. Most satellites are in low orbit, travelling at approximately 17,500 mph. When visible, they move quickly across the sky and are only in the field of view for a few minutes, requiring AudioStar to slew the telescope rapidly. Best viewing is near Sunrise or Sunset when the sky is still dark. Viewing in the middle of the night can be problematic because the satellite may pass overhead, but not be visible as it is in the Earth’s shadow.*



Looking at or near the **Sun** will cause **irreversible** damage to your eye. Do not point this telescope at or near the Sun. Do not look through the telescope as it is moving.

# APPENDIX D

## Training the Drive

Train the telescope motors using AudioStar. Perform this procedure if you are experiencing any pointing accuracy problems. **Fig. 32** depicts the complete Drive Training procedure.

**NOTE:** Use a terrestrial object, such as a telephone pole or lamp post, to train the drive. Complete this exercise once every 3 to 6 months to maintain the highest level of telescope pointing accuracy.

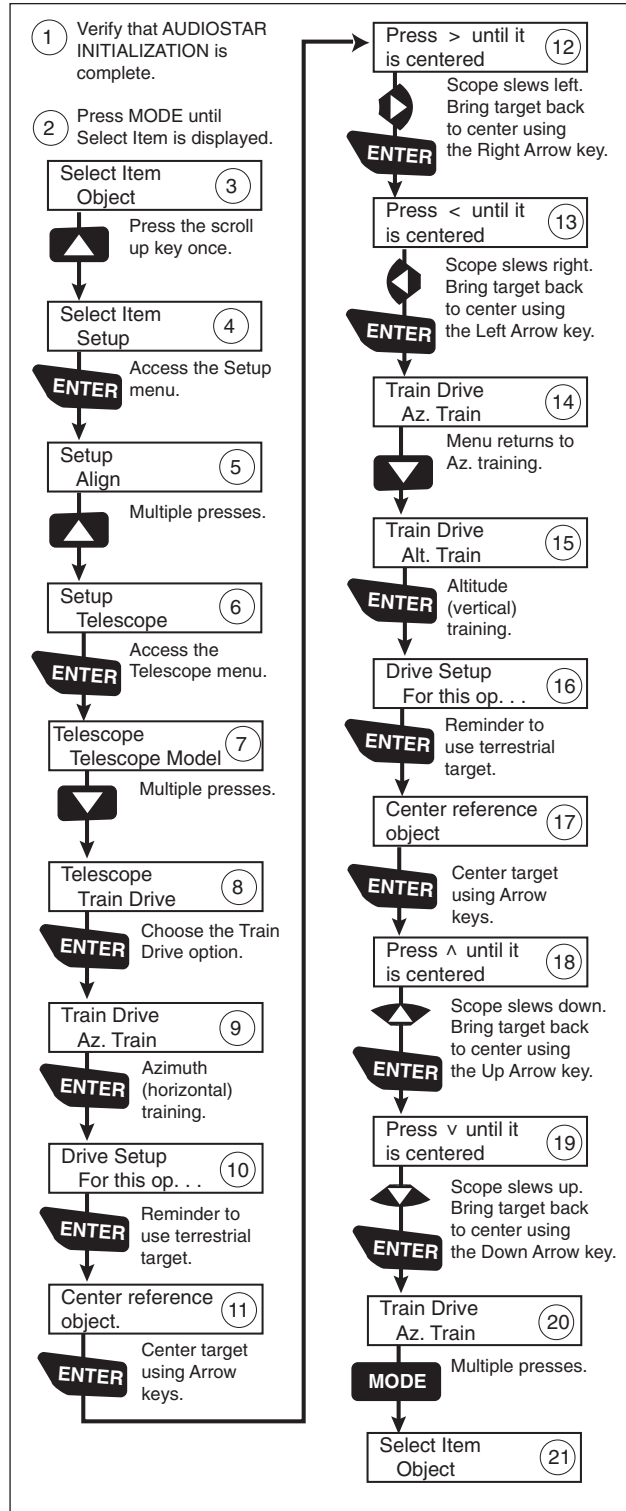

Fig. 32: Training the Drive

### STARNAVIGATOR TIPS

This manual gives only the briefest introduction to astronomy. If you are interested in pursuing further studies, a few topics are suggested below that are worth reading up on. Try looking up some of these topics in the AudioStar glossary.

Also below is a small sampling of books, magazines, and organizations that you might find helpful.

#### Topics

- How is a star born? How does a solar system form?
- How is the distance to a star measured? What is a light year? What is red shift and blue shift?
- How are the craters on our Moon formed? How old is the Moon and Earth? How old is the Sun?
- What is a black hole? A neutron star?
- What are stars made of? Why are stars different colors? What is a white dwarf? A red giant? Have we ever seen the surface of a star besides our own Sun?
- What is a nova? A supernova?
- What are comets? Minor planets? Meteors? Meteor showers? Where do they come from?
- What is a planetary nebula? A globular cluster?
- What is the Big Bang? Is the universe expanding or contracting, or does it always remain the same? What is dark matter?
- What is an extrasolar planet? What is an accretion (or protoplanetary) disk?
- What is the difference between an elliptical, a spiral, and an irregular galaxy?

#### Magazines

- Sky & Telescope*  
Box 9111, Belmont, MA 02178
- Astronomy*  
Box 1612, Waukesha, WI 53187

Looking at or near the Sun will cause irreversible damage to your eye. Do not point this telescope at or near the Sun. Do not look through the telescope as it is moving.



## APPENDIX E

### Red Dot - Replacing the Battery

Replace the red dot Viewfinder's battery with a CR2032 lithium battery. The battery is located inside the body of the red dot viewfinder. You can push out the battery tray with a coin or fingernail and then slide it out.

Replace the internal clock's battery with a CR2032 lithium battery. This battery is located in the battery compartment.

Both batteries are available from photographic supply houses or any place lithium batteries are sold.

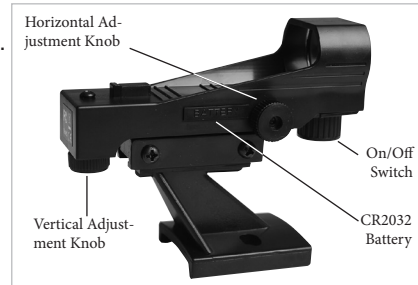

Fig. 33: Red Dot Viewfinder.

## APPENDIX F

### How to manually set the date to March 6, 2007:

1. Press ON/OFF to turn on the control panel.
2. Press the button prompted by the control panel to show that the Sun warning has been read and understood. Press ENTER to bypass Getting Started message.
3. Keep pressing MODE until "Select Item: Object" displays.
4. Keep pressing the Scroll Down key until "Select Item: Setup" displays. Press ENTER.
5. Keep pressing the Scroll Down key until "Setup: Date" displays. Press ENTER.
6. "Enter Date: 01-JAN-2003" displays. "0" is highlighted by a blinking cursor. Press the Right Arrow key to move to the next position.
7. "1" is now highlighted. Press the Number key "6."
8. "JAN" is now highlighted. Press the Scroll Up key until "MAR" displays. Press the Right Arrow key to move to the next position.
9. "2" is now highlighted. The date display now reads "06 MAR 2003." Press the Right Arrow key three times until the "3" is highlighted.
10. Press the Number key "7." Press ENTER. The date is now entered.

### How to manually set the time to 11:30 p.m.

If you have just set the date, "Setup: Date" displays. Press DOWN once and "Setup: Time" displays. Then proceed to step #6. below.

If you have not yet turned on your control panel, begin with step #1.

1. Press ON/OFF to turn on the control panel.
2. Press the button prompted by the control panel to show that the Sun warning has been read and understood. Press ENTER to bypass Getting Started message.
3. Keep pressing MODE until "Select Item: Object" displays.
4. Keep pressing the Scroll Down key until "Select Item: Setup" displays. Press ENTER.
5. Keep pressing the Scroll Down key until "Setup: Time" displays. Press ENTER.
6. "Enter Time: 08:00:00AM" displays. The leftmost "0" is highlighted. Press the Number key "1."
7. "8" is highlighted. Press the Number key "1."
8. "0" is highlighted. Press the Number key "3."
9. The time display now reads "11:30:00AM." Press the Right Arrow key until "AM" is highlighted. Press one of the Arrow Keys until "PM" displays. Press ENTER. The time is now entered.



Looking at or near the **Sun** will cause **irreversible** damage to your eye. Do not point this telescope at or near the Sun. Do not look through the telescope as it is moving.

# BASIC ASTRONOMY

In the early 17th century Italian Scientist Galileo, using a telescope smaller than your StarNavigator NG model, turned it skyward instead of looking at the distant trees and mountains. What he saw, and what he realized about what he saw, has forever changed the way mankind thinks about the universe. Imagine what it must have been like being the first human to see moons revolve around the planet Jupiter or to see the changing phases of Venus! Because of his observations, Galileo correctly realized Earth's movement and position around the Sun, and in doing so, gave birth to modern astronomy. Yet Galileo's telescope was so crude, he could not clearly make out the rings of Saturn.

Galileo's discoveries laid the foundation for understanding the motion and nature of the planets, stars, and galaxies. Building on his foundation, Henrietta Leavitt determined how to measure the distance to stars, Edwin Hubble gave us a glimpse into the possible origin of the universe, Albert Einstein unraveled the crucial relationship of time and light, and 21st-century astronomers are currently discovering planets around stars outside our solar system. Almost daily, using sophisticated successors to Galileo's telescope, such as the Hubble Space Telescope and the Chandra X-Ray Telescope, more and more mysteries of the universe are being probed and understood. We are living in the golden age of astronomy.

Unlike other sciences, astronomy welcomes contributions from amateurs. Much of the knowledge we have on subjects such as comets, meteor showers, variable stars, the Moon, and our solar system comes from observations made by amateur astronomers. So as you look through your Meade StarNavigator NG telescope, keep in mind Galileo. To him, a telescope was not merely a machine made of glass and metal, but something far more—a window through which the beating heart of the universe might be observed.

## AudioStar Glossary

Be sure to make use of AudioStar's Glossary feature. The Glossary menu provides an alphabetical listing of definitions and descriptions of common astronomical terms. Access directly through the Glossary menu or through hypertext words embedded in AudioStar. See **GLOSSARY MENU**, page 27, for more information.

## Objects in Space

Listed below are some of the many astronomical objects that can be seen with the StarNavigator NG Series Telescope:

### The Moon

The Moon is, on average, a distance of 239,000 miles (380,000km) from Earth and is best observed during its crescent or half phase when Sunlight strikes the Moon's surface at an angle. It casts shadows and adds a sense of depth to the view (**Fig. 34**). No shadows are seen during a full Moon, causing the overly bright Moon to appear flat and rather uninteresting through the telescope. Be sure to use a neutral Moon filter when observing the Moon. Not only does it protect your eyes from the bright glare of the Moon, but it also helps enhance contrast, providing a more dramatic image.

Brilliant detail can be observed on the Moon, including hundreds of lunar craters and maria, described below.

**Craters** are round meteor impact sites covering most of the Moon's surface. With no atmosphere on the Moon, no weather conditions exist, so the only erosive force is meteor strikes. Under these conditions, lunar craters can last for millions of years.

**Maria** (plural for mare) are smooth, dark areas scattered across the lunar surface. These dark areas are large ancient impact basins that were filled with lava from the interior of the Moon by the depth and force of a meteor or comet impact.

Twelve Apollo astronauts left their bootprints on the Moon in the late 1960's and early 1970's. However, no telescope on Earth is able to see these footprints or any other artifacts. In fact, the smallest lunar features that may be seen with the largest telescope on Earth are about one-half mile across.



Fig. 34: The Moon.  
Note the deep shadows in the craters.

 Looking at or near the **Sun** will cause **irreversible** damage to your eye. Do not point this telescope at or near the Sun. Do not look through the telescope as it is moving.

## Planets

Planets change positions in the sky as they orbit around the Sun. To locate the planets on a given day or month, consult a monthly astronomy magazine, such as *Sky and Telescope* or *Astronomy*. You can also consult AudioStar for information about planets. Scroll to the “Object: Solar System” menu and scroll through the lists of planets. When a planet you are interested in displays, press ENTER. Use the Scroll keys to display information about the planet, such as the planet’s coordinates, and the rise and set times (**Tip:** enter a date in the Date menu and you can determine if a planet(s) will be visible during the night of the entered date by checking its rise and set times). Listed below are the best planets for viewing through the StarNavigator NG Series.



*Fig. 35: Jupiter and its four largest moons. The moons can be observed in a different position every night.*



*Fig. 36: Saturn has the most extensive ring structure in our Solar System.*

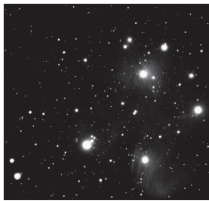

*Fig. 37: The Pleiades is one of the most beautiful open clusters.*

**Venus** is about nine-tenths the diameter of Earth. As Venus orbits the Sun, observers can see it go through phases (crescent, half, and full) much like those of the Moon. The disk of Venus appears white as sunlight is reflected off the thick cloud cover that completely obscures any surface detail.

**Mars** is about half the diameter of Earth, and appears through the telescope as a tiny reddish-orange disk. It may be possible to see a hint of white at one of the planet’s Polar ice caps. Approximately every two years, when Mars is closest to Earth in its orbit, additional detail and coloring on the planet’s surface may be visible.

**Jupiter** is the largest planet in our solar system and is 11 times the diameter of Earth. The planet appears as a disk with dark lines stretching across the surface. These lines are cloud bands in the atmosphere. Four of Jupiter’s 16 moons (Io, Europa, Ganymede, and Callisto) can be seen as “star-like” points of light when using even the lowest magnification (**Fig. 35**). These moons orbit Jupiter so that the number of moons visible on any given night changes as they circle around the giant planet.

**Saturn** is nine times the diameter of Earth and appears as a small, round disk with rings extending out from either side (**Fig. 36**). In 1610, Galileo, the first person to observe Saturn through a telescope, did not understand that what he was seeing were rings. Instead, he believed that Saturn had “ears.” Saturn’s rings are composed of billions of ice particles ranging in size from a speck of dust to the size of a house. The major division in Saturn’s rings, called the Cassini Division, is occasionally visible. Titan, the largest of Saturn’s 18 moons can also be seen as a bright, star-like object near the planet.

## Deep-Sky Objects

Star charts can be used to locate constellations, individual stars and deep-sky objects. Examples of various deep-sky objects are given below:

**Stars** are large gaseous objects that are self-illuminated by nuclear fusion in their core. Because of their vast distances from our solar system, all stars appear as pinpoints of light, irrespective of the size of the telescope used.

**Nebulae** are vast interstellar clouds of gas and dust where stars are formed. Most impressive of these is the Great Nebula in Orion (M42), a diffuse nebula that appears as a faint wispy gray cloud. M42 is 1600 light years from Earth.

**Open Clusters** are loose groupings of young stars, all recently formed from the same diffuse nebula. The Pleiades is an open cluster 410 light years away (**Fig. 37**).

**Constellations** are large, imaginary patterns of stars believed by ancient civilizations to be the celestial equivalent of objects, animals, people, or gods. These patterns are too large to be seen through a telescope. To learn the constellations, start with an easy grouping of stars, such as the Big Dipper in Ursa Major. Then, use a star chart to explore across the sky.

**Galaxies** are large assemblies of stars, nebulae, and star clusters that are bound by gravity. The most common shape is spiral (such as our own Milky Way), but galaxies can also be elliptical, or even irregular blobs. The Andromeda Galaxy (M31) is the closest spiral-type galaxy to our own. This galaxy appears fuzzy and cigar-shaped. It is 2.2 million light years away in the constellation Andromeda, located between the large “W” of Cassiopeia and the great square of Pegasus.

 Looking at or near the **Sun** will cause **irreversible** damage to your eye. Do not point this telescope at or near the Sun. Do not look through the telescope as it is moving.



## MEADE LIMITED WARRANTY

Every Meade telescope, spotting scope, and telescope accessory is warranted by Meade Instruments Corporation ("Meade") to be free of defects in materials and workmanship for a period of ONE YEAR from the date of original purchase in the U.S.A. and Canada. Meade will repair or replace a product, or part thereof, found by Meade to be defective, provided the defective part is returned to Meade, freight-prepaid, with proof of purchase. This warranty applies to the original purchaser only and is non-transferable. Meade products purchased outside North America are not included in this warranty, but are covered under separate warranties issued by Meade international distributors.

**RGA Number Required:** Prior to the return of any product or part, a Return Goods Authorization (RGA) number **must** be obtained from Meade by writing, or calling (800) 626-3233. Each returned part or product must include a written statement detailing the nature of the claimed defect, as well as the owner's name, address, and phone number.

This warranty is not valid in cases where the product has been abused or mishandled, where unauthorized repairs have been attempted or performed, or where depreciation of the product is due to normal wear-and-tear. Meade specifically disclaims special, indirect, or consequential damages or lost profit which may result from a breach of this warranty. Any implied warranties which cannot be disclaimed are hereby limited to a term of one year from the date of original retail purchase.

This warranty gives you specific rights. You may have other rights which vary from state to state.

Meade reserves the right to change product specifications or to discontinue products without notice.

This warranty supercedes all previous Meade product warranties.



# We appreciate your business. Keep in touch!

Let's Get Social:



@MeadeInstruments



@MeadeInstruments



@MeadeInstrument

Share your photos with us:

**#MeadePhotos**  
**Social@meade.com**

For special offers and other products, visit our website:

**www.meade.com**



**MEADE®**

27 Hubble, Irvine, California 92618  
(800) 626-3233 ■ [www.meade.com](http://www.meade.com)